

**GFT 110 T3 1000**

Gearbox weight: 395 kg

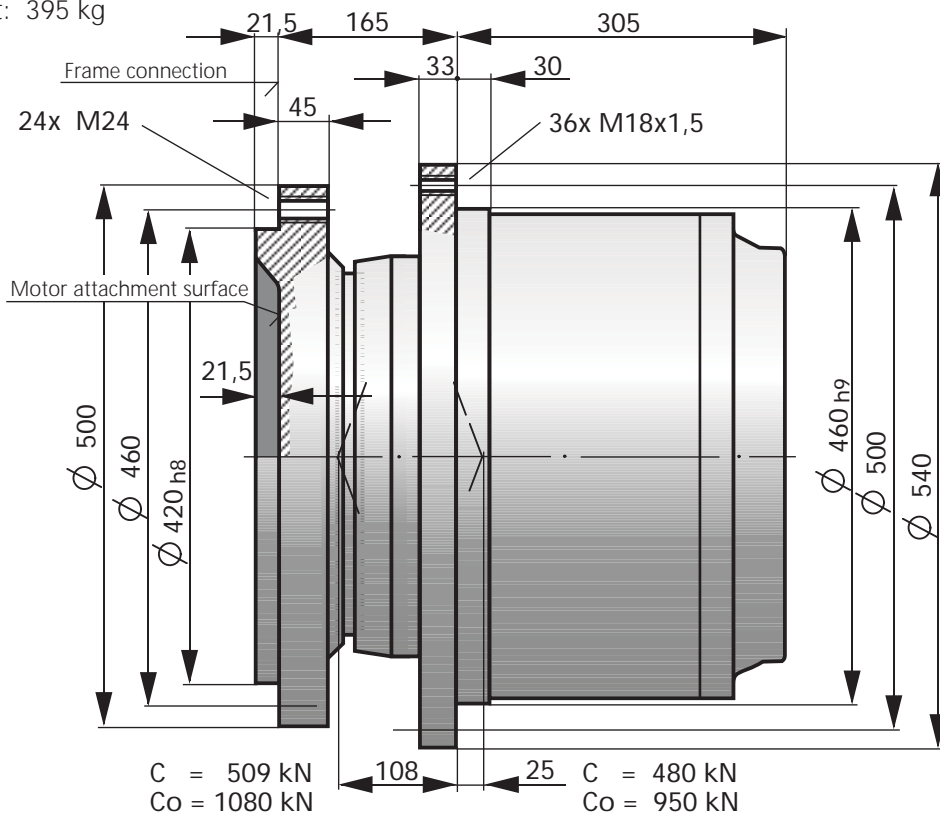

**GFT 110 T3 9000/1**

Gearbox weight: 410 kg

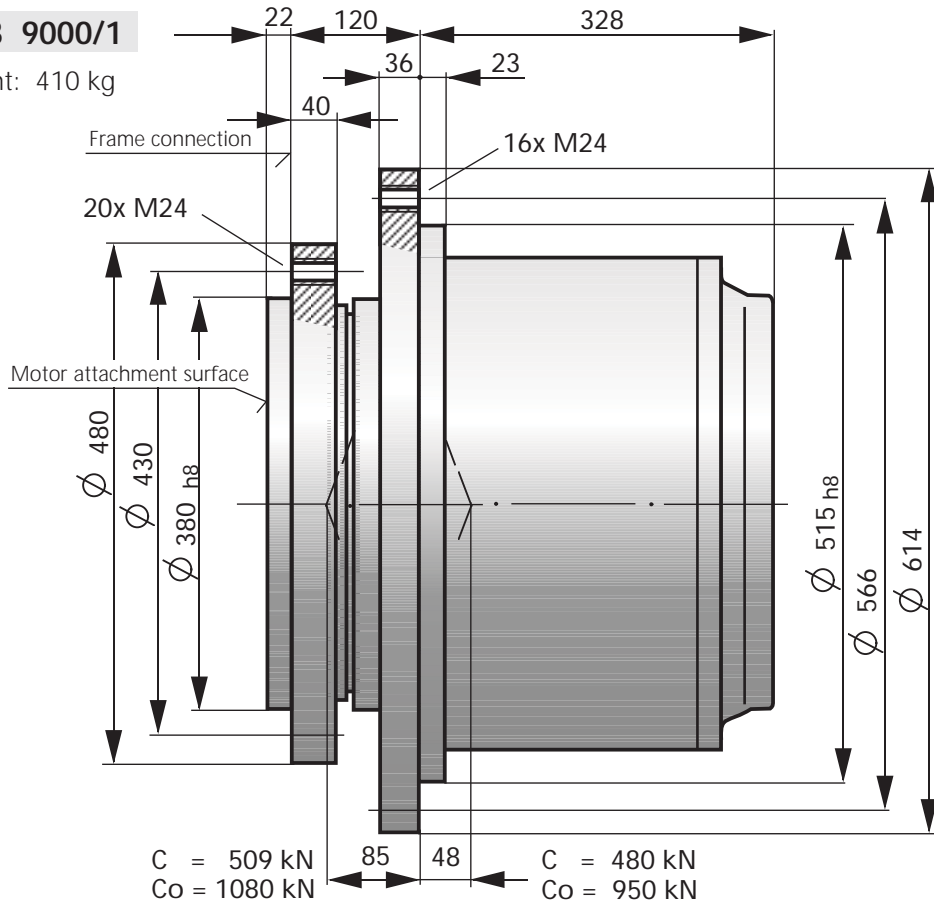

**GFT 110 T3 1000 and 9000/1 – Technical Data**

(theoretical values, without consideration of  $\eta_{\min}$  and  $\eta_v$ ; values rounded)

**GFT 110 T3 - A6VE 107 / 63W-VZL**

Motor weight: 45 kg

Transmission ratio	i		95.8	114.8	128.6	147.2	173.9	215.0
Motor displacement	$V_{g \max}$	cm <sup>3</sup>	107	107	107	107	107	107
	$V_{g \min}$	cm <sup>3</sup>	0	0	0	0	0	0
Max. torque of parking brake	$T_{Br}$	Nm	1025	1025	1025	825	740	740
Total displacement	$V_{g \text{ total}}$	cm <sup>3</sup> /rev.	10254	12286	13760	15754	18603	23005
Motor speed	at $V_{g \max}$	$n_1$	rpm	3300	3300	3300	3300	3300
	at $V_g < V_{g1}$	$n_1$	rpm	3300	4000	4500	4500	4500
		$V_{g1}$	cm <sup>3</sup> /rev.	71	71	71	71	71
Output speed	at $V_{g \max}$	$n_2$	rpm	34.4	28.7	25.7	22.4	19.0
	at $V_g < V_{g1}$	$n_2$	rpm	34.4	34.8	35.0	30.6	25.9
Inlet flow rate at $n_{\max}$	$q_{v \max}$	l/min	353	353	353	353	353	353
Differential pressure	$\Delta p$	bar	450	450	450	439	372	301
Motor torque	$T_{1 \max}$	Nm	766	766	766	747	633	512
<b>Output torque</b>	<b><math>T_{2 \max}</math></b>	<b>Nm</b>	<b>73364</b>	<b>87909</b>	<b>98454</b>	<b>110000</b>	<b>110000</b>	<b>110000</b>

**GFT 110 T3 - A6VE 160 / 63W-VZL**

Motor weight: 64 kg

Transmission ratio	i		95.8	114.8	128.6	147.2	173.9	215.0
Motor displacement	$V_{g \max}$	cm <sup>3</sup>	160	160	160	160	160	160
	$V_{g \min}$	cm <sup>3</sup>	0	0	0	0	0	0
Max. torque of parking brake	$T_{Br}$	Nm	1025	1025	1025	825	740	740
Total displacement	$V_{g \text{ total}}$	cm <sup>3</sup> /rev.	15332	18372	20576	23558	27817	34400
Motor speed	at $V_{g \max}$	$n_1$	rpm	3000	3000	3000	3000	3000
	at $V_g < V_{g1}$	$n_1$	rpm	3300	4000	4500	4500	4500
		$V_{g1}$	cm <sup>3</sup> /rev.	107	107	107	107	107
Output speed	at $V_{g \max}$	$n_2$	rpm	31.3	26.1	23.3	20.4	17.3
	at $V_g < V_{g1}$	$n_2$	rpm	34.4	34.8	35.0	30.6	25.9
Inlet flow rate at $n_{\max}$	$q_{v \max}$	l/min	480	480	480	480	480	480
Differential pressure	$\Delta p$	bar	450	377	336	294	249	201
Motor torque	$T_{1 \max}$	Nm	1145	958	855	747	633	512
<b>Output torque</b>	<b><math>T_{2 \max}</math></b>	<b>Nm</b>	<b>109703</b>	<b>110000</b>	<b>110000</b>	<b>110000</b>	<b>110000</b>	<b>110000</b>

**GFT 110 T3 1000**

Gearbox weight: 395 kg

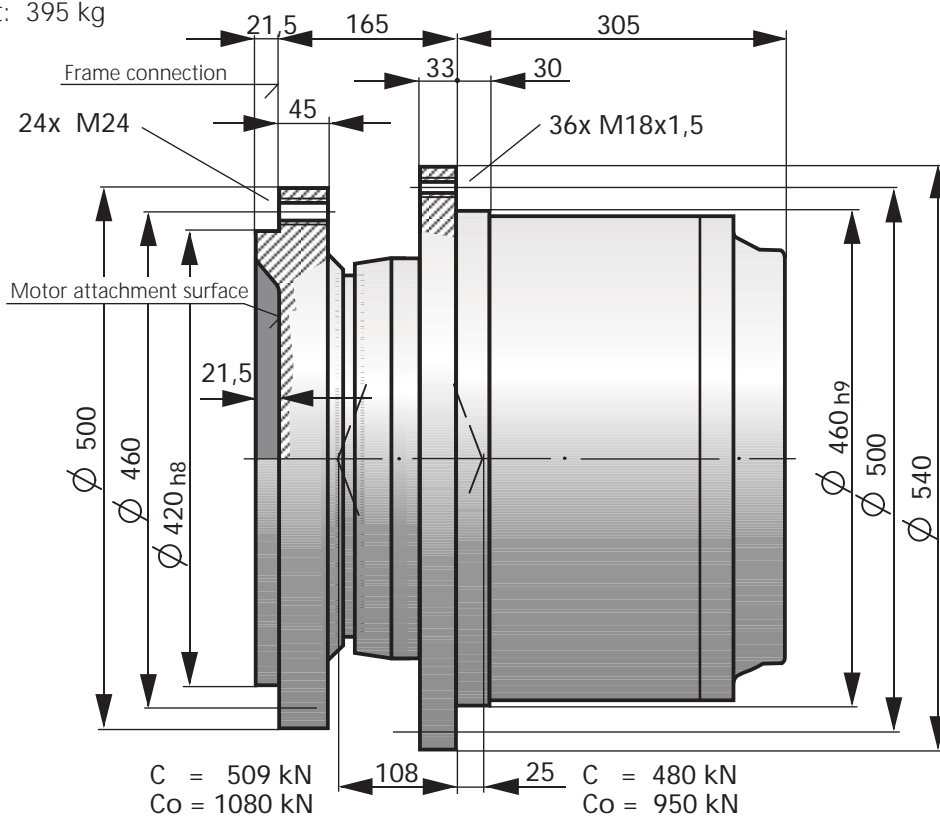

**GFT 110 T3 9000/1**

Gearbox weight: 410 kg

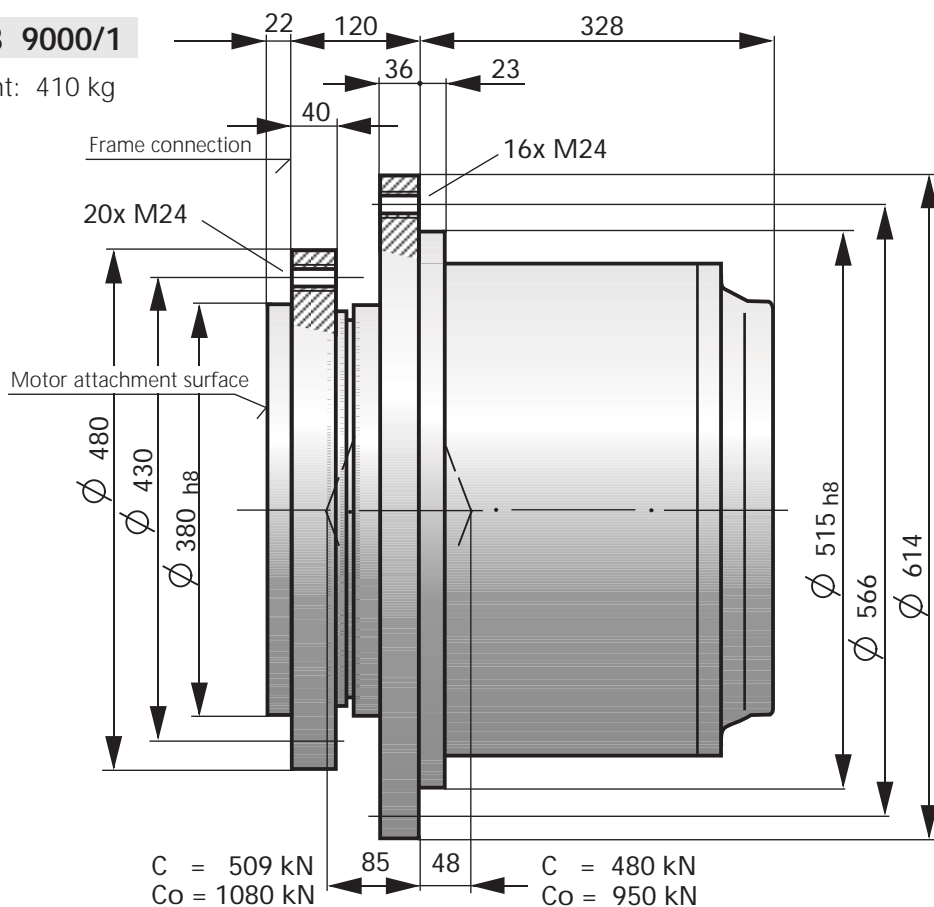

**GFT 110 T3 1000 and 9000/1 – Technical Data**

(theoretical values, without consideration of  $\eta_{min}$  and  $\eta_v$ ; values rounded)

**GFT 110 T3 - A2FE 107 / 61W-VZL**

Motor weight: 34 kg

Transmission ratio	i		95.8	114.8	128.6	147.2	173.9	215.0
Motor displacement	$V_g$	cm <sup>3</sup>	106.7	106.7	106.7	106.7	106.7	106.7
Max. torque of parking brake	$T_{Br}$	Nm	1025	1025	1025	825	740	740
Total displacement	$V_{g\ total}$	cm <sup>3</sup> /rev.	10225	12252	13722	15710	18551	22941
Motor speed	$n_1$	rpm	3300	4000	4000	4000	4000	4000
Output speed	$n_2$	rpm	34.4	34.8	31.1	27.2	23.0	18.6
Inlet flow rate at $n_{max}$	$q_{v\ max}$	l/min	352	427	427	427	427	427
Differential pressure	$\Delta p$	bar	450	450	450	440	373	302
Motor torque	$T_{1\ max}$	Nm	763	763	763	747	633	512
<b>Output torque</b>	<b><math>T_{2\ max}</math></b>	<b>Nm</b>	<b>73158</b>	<b>87663</b>	<b>98178</b>	<b>110000</b>	<b>110000</b>	<b>110000</b>

**GFT 110 T3 - A2FE 125 / 61W-VZL**

Motor weight: 36 kg

Transmission ratio	i		95.8	114.8	128.6	147.2	173.9	215.0
Motor displacement	$V_g$	cm <sup>3</sup>	125	125	125	125	125	125
Max. torque of parking brake	$T_{Br}$	Nm	1025	1025	1025	825	740	740
Total displacement	$V_{g\ total}$	cm <sup>3</sup> /rev.	11978	14353	16075	18404	21732	26875
Motor speed	$n_1$	rpm	3300	4000	4000	4000	4000	4000
Output speed	$n_2$	rpm	34.4	34.8	31.1	27.2	23.0	18.6
Inlet flow rate at $n_{max}$	$q_{v\ max}$	l/min	413	500	500	500	500	500
Differential pressure	$\Delta p$	bar	450	450	430	376	318	257
Motor torque	$T_{1\ max}$	Nm	894	894	855	747	633	512
<b>Output torque</b>	<b><math>T_{2\ max}</math></b>	<b>Nm</b>	<b>85706</b>	<b>102698</b>	<b>110000</b>	<b>110000</b>	<b>110000</b>	<b>110000</b>

**GFT 110 T3 - A2FE 160 / 61W-VZL**

Motor weight: 47 kg

Transmission ratio	i		95.8	114.8	128.6	147.2	173.9	215.0
Motor displacement	$V_g$	cm <sup>3</sup>	160.4	160.4	160.4	160.4	160.4	160.4
Max. torque of parking brake	$T_{Br}$	Nm	1025	1025	1025	825	740	740
Total displacement	$V_{g\ total}$	cm <sup>3</sup> /rev.	15371	18418	20627	23617	27887	34486
Motor speed	$n_1$	rpm	3300	3600	3600	3600	3600	3600
Output speed	$n_2$	rpm	34.4	31.4	28.0	24.5	20.7	16.7
Inlet flow rate at $n_{max}$	$q_{v\ max}$	l/min	529	577	577	577	577	577
Differential pressure	$\Delta p$	bar	450	376	335	293	248	201
Motor torque	$T_{1\ max}$	Nm	1148	958	855	747	633	512
<b>Output torque</b>	<b><math>T_{2\ max}</math></b>	<b>Nm</b>	<b>109978</b>	<b>110000</b>	<b>110000</b>	<b>110000</b>	<b>110000</b>	<b>110000</b>

**GFT 110 T3 - A2FE 180 / 61W-VZL**

Motor weight: 48 kg

Transmission ratio	i		95.8	114.8	128.6	147.2	173.9	215.0
Motor displacement	$V_g$	cm <sup>3</sup>	180	180	180	180	180	180
Max. torque of parking brake	$T_{Br}$	Nm	1025	1025	1025	825	740	740
Total displacement	$V_{g\ total}$	cm <sup>3</sup> /rev.	17249	20669	23148	26502	31294	38700
Motor speed	$n_1$	rpm	3300	3600	3600	3600	3600	3600
Output speed	$n_2$	rpm	34.4	31.4	28.0	24.5	20.7	16.7
Inlet flow rate at $n_{max}$	$q_{v\ max}$	l/min	405	405	405	405	405	405
Differential pressure	$\Delta p$	bar	401	335	299	261	221	179
Motor torque	$T_{1\ max}$	Nm	1148	958	855	747	633	512
<b>Output torque</b>	<b><math>T_{2\ max}</math></b>	<b>Nm</b>	<b>110000</b>	<b>110000</b>	<b>110000</b>	<b>110000</b>	<b>110000</b>	<b>110000</b>

**GFT 110 T3 9000/3**

Gearbox weight: 505 kg

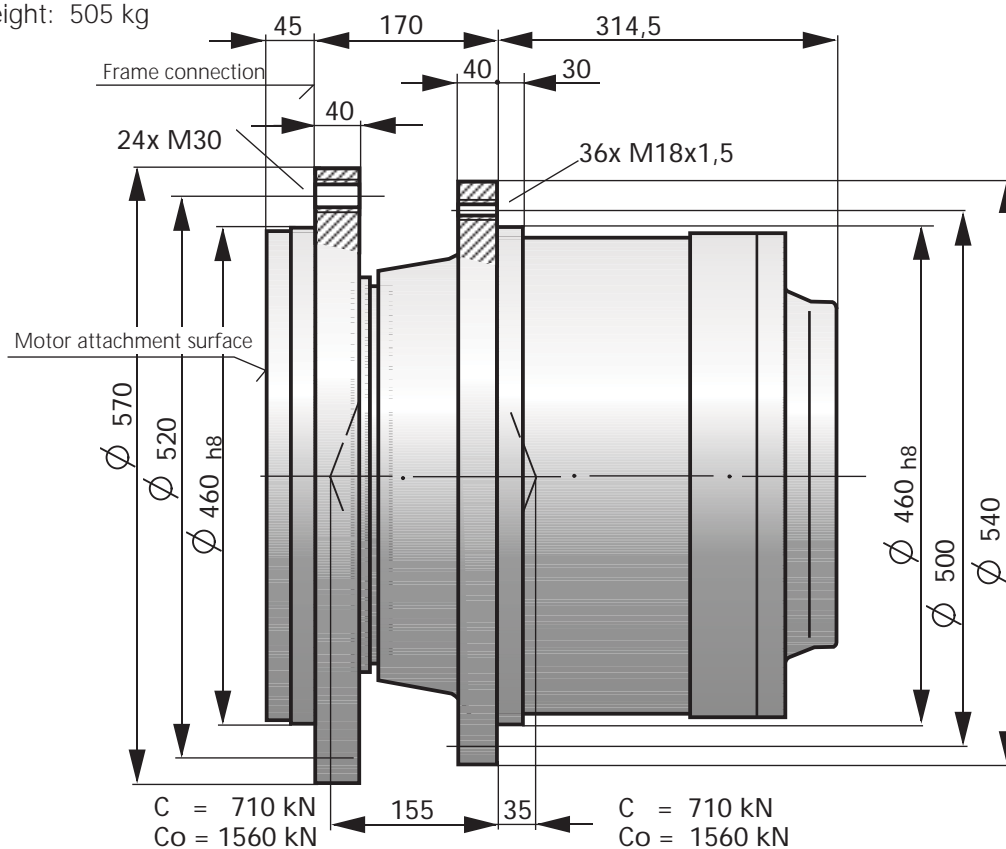

**GFT 110 T3 9000/3 – Technical Data**

(theoretical values, without consideration of  $\eta_{\min}$  and  $\eta_v$ ; values rounded)

**GFT 110 T3 - A6VE 107 / 63W-VZL**

Motor weight: 45 kg

Transmission ratio			<b>i</b>	<b>95.8</b>	<b>114.8</b>	<b>128.6</b>	<b>147.2</b>	<b>173.9</b>	<b>215.0</b>
Motor displacement	$V_{g \max}$	cm <sup>3</sup>	107	107	107	107	107	107	107
	$V_{g \min}$	cm <sup>3</sup>	0	0	0	0	0	0	0
Max. torque of parking brake	$T_{Br}$	Nm	1100	1100	1100	1100	850	850	
Total displacement	$V_{g \text{ total}}$	cm <sup>3</sup> /rev.	10254	12286	13760	15754	18603	23005	
Motor speed	at $V_{g \max}$	$n_1$	rpm	3300	3300	3300	3300	3300	3300
	at $V_g < V_{g1}$	$n_1$	rpm	3300	4000	4500	4500	4500	4500
		$V_{g1}$	cm <sup>3</sup> /rev.	71	71	71	71	71	71
Output speed	at $V_{g \max}$	$n_2$	rpm	34.4	28.7	25.7	22.4	19.0	15.3
	at $V_g < V_{g1}$	$n_2$	rpm	34.4	34.8	35.0	30.6	25.9	20.9
Inlet flow rate at $n_{\max}$	$q_{v \max}$	l/min	353	353	353	353	353	353	
Differential pressure	$\Delta p$	bar	450	450	450	439	372	301	
Motor torque	$T_{1 \max}$	Nm	766	766	766	747	633	512	
<b>Output torque</b>	<b><math>T_{2 \max}</math></b>	<b>Nm</b>	<b>73364</b>	<b>87909</b>	<b>98454</b>	<b>110000</b>	<b>110000</b>	<b>110000</b>	

**GFT 110 T3 - A6VE 160 / 63W-VZL**

Motor weight: 64 kg

Transmission ratio			<b>i</b>	<b>95.8</b>	<b>114.8</b>	<b>128.6</b>	<b>147.2</b>	<b>173.9</b>	<b>215.0</b>
Motor displacement	$V_{g \max}$	cm <sup>3</sup>	160	160	160	160	160	160	160
	$V_{g \min}$	cm <sup>3</sup>	0	0	0	0	0	0	0
Max. torque of parking brake	$T_{Br}$	Nm	1025	1025	1025	825	740	740	
Total displacement	$V_{g \text{ total}}$	cm <sup>3</sup> /rev.	15332	18372	20576	23558	27817	34400	
Motor speed	at $V_{g \max}$	$n_1$	rpm	3000	3000	3000	3000	3000	3000
	at $V_g < V_{g1}$	$n_1$	rpm	3300	4000	4500	4500	4500	4500
		$V_{g1}$	cm <sup>3</sup> /rev.	107	107	107	107	107	107
Output speed	at $V_{g \max}$	$n_2$	rpm	31.3	26.1	23.3	20.4	17.3	14.0
	at $V_g < V_{g1}$	$n_2$	rpm	34.4	34.8	35.0	30.6	25.9	20.9
Inlet flow rate at $n_{\max}$	$q_{v \max}$	l/min	480	480	480	480	480	480	
Differential pressure	$\Delta p$	bar	450	377	336	294	249	201	
Motor torque	$T_{1 \max}$	Nm	1145	958	855	747	633	512	
<b>Output torque</b>	<b><math>T_{2 \max}</math></b>	<b>Nm</b>	<b>109703</b>	<b>110000</b>	<b>110000</b>	<b>110000</b>	<b>110000</b>	<b>110000</b>	

**GFT 110 T3 9000/3**

Gearbox weight: 505 kg

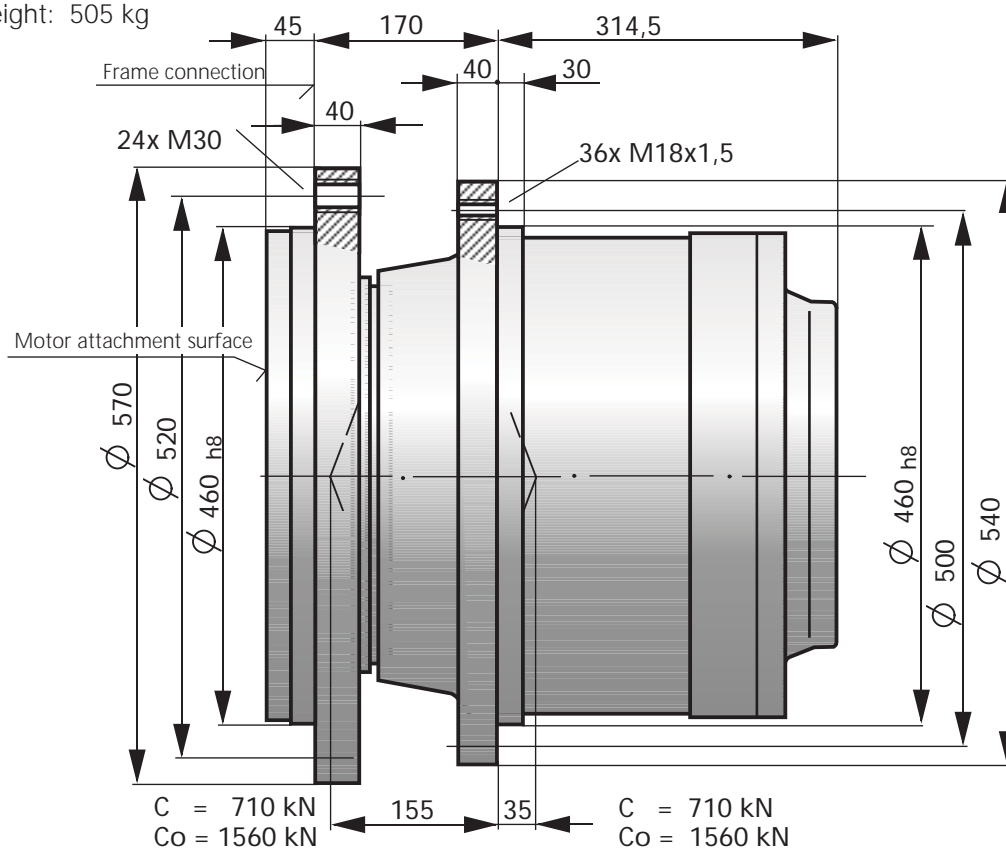

**GFT 110 T3 9000/3 – Technical Data**

(theoretical values, without consideration of  $\eta_{min}$  and  $\eta_v$ ; values rounded)

**GFT 110 T3 - A2FE 107 / 61W-VZL**

Motor weight: 34 kg

Transmission ratio	i		95.8	114.8	128.6	147.2	173.9	215.0
Motor displacement	$V_g$	cm <sup>3</sup>	106.7	106.7	106.7	106.7	106.7	106.7
Max. torque of parking brake	$T_{Br}$	Nm	1100	1100	1100	1100	850	850
Total displacement	$V_{g\ total}$	cm <sup>3</sup> /rev.	10225	12252	13722	15710	18551	22941
Motor speed	$n_1$	rpm	3300	4000	4000	4000	4000	4000
Output speed	$n_2$	rpm	34.4	34.8	31.1	27.2	23.0	18.6
Inlet flow rate at $n_{max}$	$q_{v\ max}$	l/min	352	427	427	427	427	427
Differential pressure	$\Delta p$	bar	450	450	450	440	373	302
Motor torque	$T_{1\ max}$	Nm	763	763	763	747	633	512
<b>Output torque</b>	<b><math>T_{2\ max}</math></b>	<b>Nm</b>	<b>73158</b>	<b>87663</b>	<b>98178</b>	<b>110000</b>	<b>110000</b>	<b>110000</b>

**GFT 110 T3 - A2FE 125 / 61W-VZL**

Motor weight: 36 kg

Transmission ratio	i		95.8	114.8	128.6	147.2	173.9	215.0
Motor displacement	$V_g$	cm <sup>3</sup>	125	125	125	125	125	125
Max. torque of parking brake	$T_{Br}$	Nm	1100	1100	1100	1100	850	850
Total displacement	$V_{g\ total}$	cm <sup>3</sup> /rev.	11978	14353	16075	18404	21732	26875
Motor speed	$n_1$	rpm	3300	4000	4000	4000	4000	4000
Output speed	$n_2$	rpm	34.4	34.8	31.1	27.2	23.0	18.6
Inlet flow rate at $n_{max}$	$q_{v\ max}$	l/min	413	500	500	500	500	500
Differential pressure	$\Delta p$	bar	450	450	430	376	318	257
Motor torque	$T_{1\ max}$	Nm	894	894	855	747	633	512
<b>Output torque</b>	<b><math>T_{2\ max}</math></b>	<b>Nm</b>	<b>85706</b>	<b>102698</b>	<b>110000</b>	<b>110000</b>	<b>110000</b>	<b>110000</b>

**GFT 110 T3 - A2FE 160 / 61W-VZL**

Motor weight: 47 kg

Transmission ratio	i		95.8	114.8	128.6	147.2	173.9	215.0
Motor displacement	$V_g$	cm <sup>3</sup>	160.4	160.4	160.4	160.4	160.4	160.4
Max. torque of parking brake	$T_{Br}$	Nm	1100	1100	1100	1100	850	850
Total displacement	$V_{g\ total}$	cm <sup>3</sup> /rev.	15371	18418	20627	23617	27887	34486
Motor speed	$n_1$	rpm	3300	3600	3600	3600	3600	3600
Output speed	$n_2$	rpm	34.4	31.4	28.0	24.5	20.7	16.7
Inlet flow rate at $n_{max}$	$q_{v\ max}$	l/min	529	577	577	577	577	577
Differential pressure	$\Delta p$	bar	450	376	335	293	248	201
Motor torque	$T_{1\ max}$	Nm	1148	958	855	747	633	512
<b>Output torque</b>	<b><math>T_{2\ max}</math></b>	<b>Nm</b>	<b>109978</b>	<b>110000</b>	<b>110000</b>	<b>110000</b>	<b>110000</b>	<b>110000</b>

**GFT 110 T3 - A2FE 180 / 61W-VZL**

Motor weight: 48 kg

Transmission ratio	i		95.8	114.8	128.6	147.2	173.9	215.0
Motor displacement	$V_g$	cm <sup>3</sup>	180	180	180	180	180	180
Max. torque of parking brake	$T_{Br}$	Nm	1100	1100	1100	1100	850	850
Total displacement	$V_{g\ total}$	cm <sup>3</sup> /rev.	17249	20669	23148	26502	31294	38700
Motor speed	$n_1$	rpm	3300	3600	3600	3600	3600	3600
Output speed	$n_2$	rpm	34.4	31.4	28.0	24.5	20.7	16.7
Inlet flow rate at $n_{max}$	$q_{v\ max}$	l/min	405	405	405	405	405	405
Differential pressure	$\Delta p$	bar	401	335	299	261	221	179
Motor torque	$T_{1\ max}$	Nm	1148	958	855	747	633	512
<b>Output torque</b>	<b><math>T_{2\ max}</math></b>	<b>Nm</b>	<b>110000</b>	<b>110000</b>	<b>110000</b>	<b>110000</b>	<b>110000</b>	<b>110000</b>