

GFT 36 T3 1000/1

Gearbox weight: 165 kg

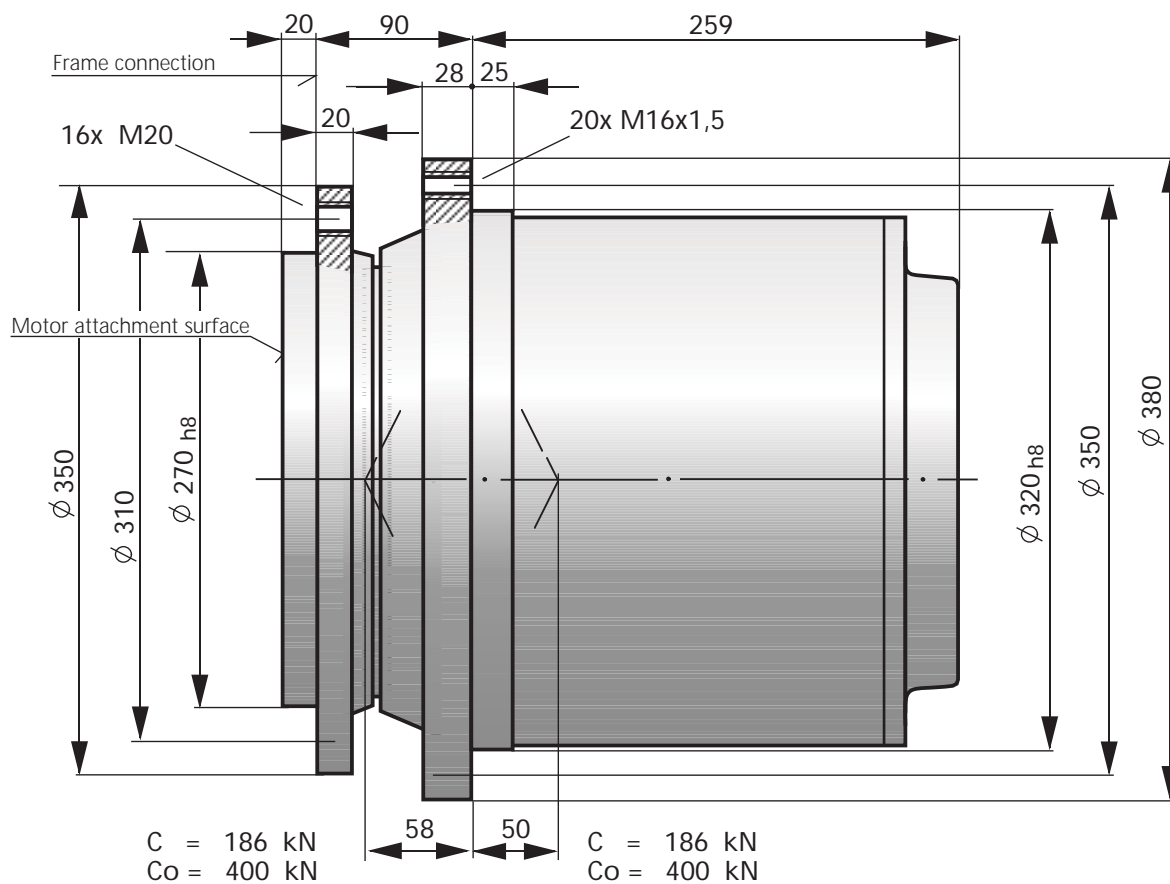

GFT 36 T3 1000/1 – Technical Data

(theoretical values, without consideration of η_{min} and η_v ; values rounded)

GFT 36 T3 - A6VE 55 / 63W-VZL

Motor weight: 26 kg

Transmission ratio	i		67.0	79.4	100.0	116.6
Motor displacement	$V_{g\ max}$	cm ³	54.8	54.8	54.8	54.8
	$V_{g\ min}$	cm ³	0	0	0	0
Max. torque of parking brake	T_{Br}	Nm	715	490	385	385
Total displacement	$V_{g\ total}$	cm ³ /rev.	3669	4349	5481	6387
Motor speed	at $V_{g\ max}$	n_1	rpm	3800	4200	4200
	at $V_{g} < V_{g\ 1}$	n_1	rpm	3800	4600	5600
		$V_{g\ 1}$	cm ³ /rev.	37	37	37
Output speed	at $V_{g\ max}$	n_2	rpm	56.8	52.9	42.0
	at $V_{g} < V_{g\ 1}$	n_2	rpm	56.8	58.0	56.0
Inlet flow rate at n_{max}	$q_{v\ max}$	l/min	208	230	230	230
Differential pressure	Δp	bar	450	450	413	354
Motor torque	$T_{1\ max}$	Nm	392	392	360	309
Output torque	$T_{2\ max}$	Nm	26254	31115	36000	36000

GFT 36 T3 - A2FE 45 / 61W-VZL

Motor weight: 15 kg

Transmission ratio	i		67.0	79.4	100.0	116.6
Motor displacement	V_g	cm ³	56.1	56.1	56.1	56.1
Max. torque of parking brake	T_{Br}	Nm	715	490	385	385
Total displacement	$V_{g\ total}$	cm ³ /rev.	3756	4452	5611	6539
Motor speed	n_1	rpm	3800	4600	5000	5000
Output speed	n_2	rpm	56.8	58.0	50.0	42.9
Inlet flow rate at n_{max}	$q_{v\ max}$	l/min	213	255	255	255
Differential pressure	Δp	bar	450	450	404	346
Motor torque	$T_{1\ max}$	Nm	401	401	360	309
Output torque	$T_{2\ max}$	Nm	26877	31854	36000	36000

GFT 36 T3 - A2FE 56 / 61W-VZL

Motor weight: 18 kg

Transmission ratio	i		67.0	79.4	100.0	116.6
Motor displacement	V_g	cm ³	56.1	56.1	56.1	56.1
Max. torque of parking brake	T_{Br}	Nm	715	490	385	385
Total displacement	$V_{g\ total}$	cm ³ /rev.	3756	4452	5611	6539
Motor speed	n_1	rpm	3800	4600	5000	5000
Output speed	n_2	rpm	56.8	58.0	50.0	42.9
Inlet flow rate at n_{max}	$q_{v\ max}$	l/min	213	258	280	280
Differential pressure	Δp	bar	450	450	404	346
Motor torque	$T_{1\ max}$	Nm	401	401	360	309
Output torque	$T_{2\ max}$	Nm	26877	31854	36000	36000

GFT 36 T3 - A2FE 63 / 61W-VZL

Motor weight: 19 kg

Transmission ratio	i		67,0	79,4	100,0	116,6
Motor displacement	V_g	cm ³	63	63	63	63
Max. torque of parking brake	T_{Br}	Nm	715	490	385	385
Total displacement	$V_{g\ total}$	cm ³ /rev.	4218	5000	6301	7343
Motor speed	n_1	rpm	3800	4500	4500	4500
Output speed	n_2	rpm	56,8	56,7	45,0	38,6
Inlet flow rate at n_{max}	$q_{v\ max}$	l/min	239	284	284	284
Differential pressure	Δp	bar	450	450	359	308
Motor torque	$T_{1\ max}$	Nm	451	451	360	309
Output torque	$T_{2\ max}$	Nm	30183	35771	36000	36000

GFT 36 T3 1000/2

Gearbox weight: 170 kg

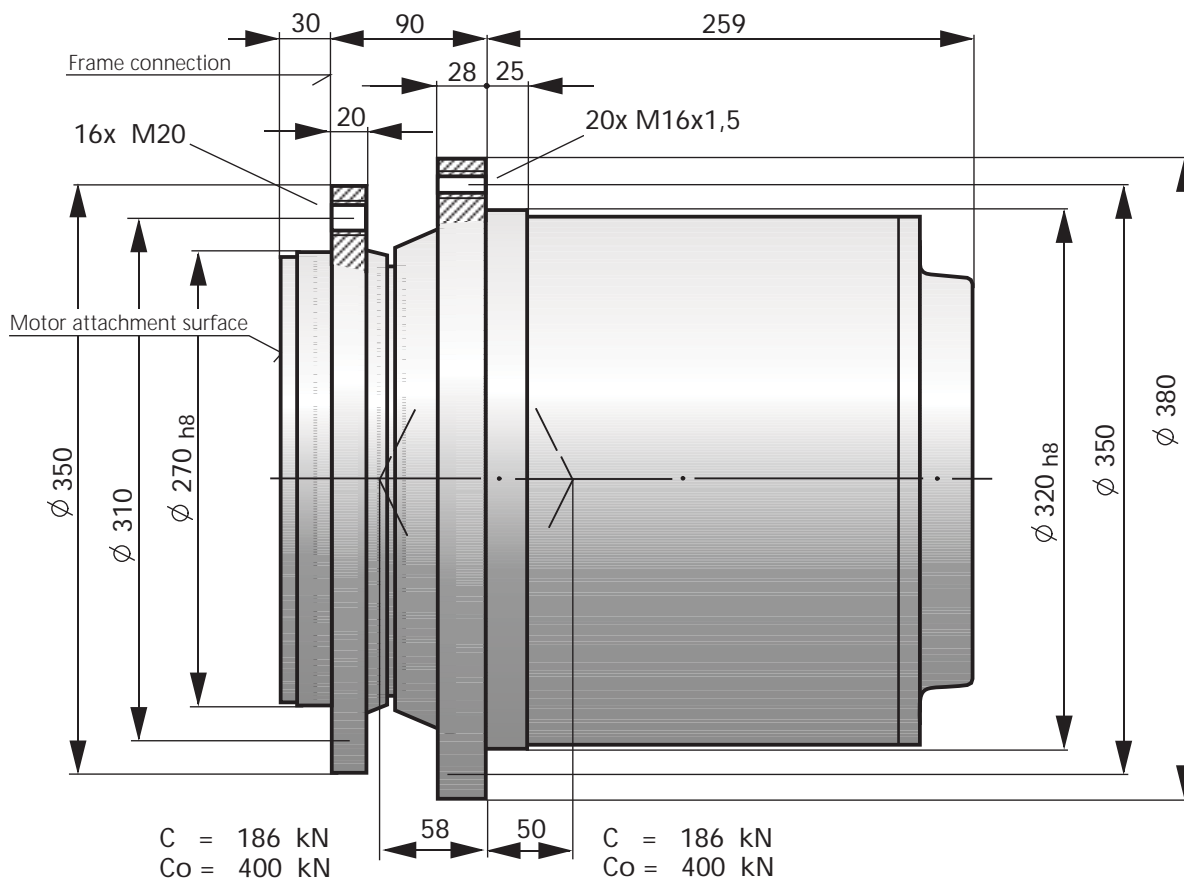

GFT 36 T3 1000/2 – Technical Data

(theoretical values, without consideration of η_{min} and η_v ; values rounded)

GFT 36 T3 - A6VE 80 / 63W-VAL

Motor weight: 34 kg

Transmission ratio	i		67.0	79.4	100.0	116.6
Motor displacement	$V_{g\ max}$	cm ³	80	80	80	80
	$V_{g\ min}$	cm ³	0	0	0	0
Max. torque of parking brake	T_{Br}	Nm	715	490	385	385
Total displacement	$V_{g\ total}$	cm ³ /rev.	5357	6349	8002	9324
Motor speed	at $V_{g\ max}$	n_1	rpm	3750	3750	3750
	at $V_g < V_{g1}$	n_1	rpm	3800	4600	5600
Output speed		V_{g1}	cm ³ /rev.	54	54	54
	at $V_{g\ max}$	n_2	rpm	56.0	47.3	37.5
	at $V_g < V_{g1}$	n_2	rpm	56.8	58.0	48.0
Inlet flow rate at n_{max}	$q_{v\ max}$	l/min	300	300	300	300
Differential pressure	Δp	bar	423	357	283	243
Motor torque	$T_{1\ max}$	Nm	538	454	360	309
Output torque	$T_{2\ max}$	Nm	36000	36000	36000	36000

GFT 36 T3 - A2FE 80 / 61W-VAL

Motor weight: 23 kg

Transmission ratio	i		67.0	79.4	100.0	116.6
Motor displacement	V_g	cm ³	80.4	80.4	80.4	80.4
Max. torque of parking brake	T_{Br}	Nm	715	490	385	385
Total displacement	$V_{g\ total}$	cm ³ /rev.	5384	6380	8042	9371
Motor speed	n_1	rpm	3800	4500	4500	4500
Output speed	n_2	rpm	56.8	56.7	45.0	38.6
Inlet flow rate at n_{max}	$q_{v\ max}$	l/min	306	360	360	360
Differential pressure	Δp	bar	421	355	282	242
Motor torque	$T_{1\ max}$	Nm	538	454	360	309
Output torque	$T_{2\ max}$	Nm	36000	36000	36000	36000

GFT 36 T3 - A2FE 90 / 61W-VAL

Motor weight: 25 kg

Transmission ratio	i		67.0	79.4	100.0	116.6
Motor displacement	V_g	cm ³	90	90	90	90
Max. torque of parking brake	T_{Br}	Nm	715	490	385	385
Total displacement	$V_{g\ total}$	cm ³ /rev.	6026	7142	9002	10490
Motor speed	n_1	rpm	3800	4500	4500	4500
Output speed	n_2	rpm	56.8	56.7	45.0	38.6
Inlet flow rate at n_{max}	$q_{v\ max}$	l/min	342	405	405	405
Differential pressure	Δp	bar	376	317	252	216
Motor torque	$T_{1\ max}$	Nm	538	454	360	309
Output torque	$T_{2\ max}$	Nm	36000	36000	36000	36000