





311L
M₂ = 35000 Nm

	i	M _{n2} [Nm]						P ₁ [kW]	P _t [kW]	n ₁ [min ⁻¹]	n _{1max} [min ⁻¹]	M _b [Nm]	
		n ₂ ·h 10 000	n ₂ ·h 25 000	n ₂ ·h 50 000	n ₂ ·h 100 000	n ₂ ·h 500 000	n ₂ ·h 1 000 000						
L1	4.09	45 000	45 000	37 400	30 300	18 700	15 200	180	35	750	1 000		
	5.25	43 000	36 500	32 300	32 000	19 700	16 000	180	35	750	1 000		
	6.23	34 000	29 500	27 000	27 000	18 600	15 100	180	35	750	1 000		
L2	14.0	35 700	35 700	35 700	30 300	18 700	15 200	100	25	1 500	2 500	3 200	6L
	16.7	45 000	45 000	37 400	30 300	18 700	15 200	100	25	1 500	2 500	3 200	6L
	18.0	43 000	36 500	32 300	32 000	19 700	16 000	100	25	1 500	2 500	2 600	6K
	21.5	44 100	41 700	37 400	30 300	18 700	15 200	100	25	1 500	2 500	2 100	6G
	25.5	35 200	34 500	34 500	30 300	18 700	15 200	100	25	1 500	2 500	1 500	6E
	27.6	43 000	36 500	32 300	32 000	19 700	16 000	100	25	1 500	2 500	2 100	6G
	32.7	43 000	36 500	32 300	32 000	19 700	16 000	100	25	1 500	2 500	1 500	6E
	38.8	34 000	29 500	27 000	27 000	18 600	15 100	100	25	1 500	2 500	850	6B
	L3	50.5	35 700	35 700	35 700	30 300	18 700	15 200	60	18	1 800	3 800	800
60.2		45 000	45 000	37 400	30 300	18 700	15 200	60	18	1 800	3 800	800	5G
71.1		45 000	45 000	37 400	30 300	18 700	15 200	60	18	1 800	3 800	800	5G
77.3		44 100	41 700	37 400	30 300	18 700	15 200	60	18	1 800	3 800	800	5G
87.0		35 700	35 700	35 700	30 300	18 700	15 200	60	18	1 800	3 800	500	5C
104		45 000	45 000	37 400	30 300	18 700	15 200	60	18	1 800	3 800	500	5C
115		44 100	41 700	37 400	30 300	18 700	15 200	60	18	1 800	3 800	400	5B
126		45 000	45 000	37 400	30 300	18 700	15 200	60	18	1 800	3 800	400	5B
133		44 100	41 700	37 400	30 300	18 700	15 200	56	18	1 800	3 800	400	5B
147		43 000	36 500	32 300	32 000	19 700	16 000	50	18	1 800	3 800	400	5B
161		44 100	41 700	37 400	30 300	18 700	15 200	48	18	1 800	3 800	400	5B
171		43 000	36 500	32 300	32 000	19 700	16 000	44	18	1 800	3 800	400	5B
191		35 200	34 500	34 500	30 300	18 700	15 200	33	18	1 800	3 800	400	5B
203		43 000	36 500	32 300	32 000	19 700	16 000	38	18	1 800	3 800	400	5B
245	43 000	36 500	32 300	32 000	19 700	16 000	32	18	1 800	3 800	400	5B	
291	34 000	29 500	27 000	27 000	18 600	15 100	22	18	1 800	3 800	400	5B	
L4	348	45 000	45 000	37 400	30 300	18 700	15 200	30	11	2 000	4 000	160	4D
	410	45 000	45 000	37 400	30 300	18 700	15 200	30	11	2 000	4 000	160	4D
	512	45 000	45 000	37 400	30 300	18 700	15 200	26	11	2 000	4 000	100	4B
	568	44 100	41 700	37 400	30 300	18 700	15 200	23	11	2 000	4 000	100	4B
	626	35 700	35 700	35 700	30 300	18 700	15 200	16.9	11	2 000	4 000	100	4B
	724	45 000	45 000	37 400	30 300	18 700	15 200	18.4	11	2 000	4 000	100	4B
	825	44 100	41 700	37 400	30 300	18 700	15 200	16.1	11	2 000	4 000	100	4B
	904	45 000	45 000	37 400	30 300	18 700	15 200	14.7	11	2 000	4 000	50	4A
	986	43 000	36 500	32 300	32 000	19 700	16 000	13.5	11	2 000	4 000	50	4A
	1 103	35 200	34 500	34 500	30 300	18 700	15 200	11.8	11	2 000	4 000	50	4A
	1 230	43 000	36 500	32 300	32 000	19 700	16 000	10.8	11	2 000	4 000	50	4A
	1 415	43 000	36 500	32 300	32 000	19 700	16 000	9.4	11	2 000	4 000	50	4A
	1 680	34 000	29 500	27 000	27 000	18 600	15 100	7.9	11	2 000	4 000	50	4A
	1 766	43 000	36 500	32 300	32 000	19 700	16 000	7.5	11	2 000	4 000	50	4A
	2 096	34 000	29 500	27 000	27 000	18 600	15 100	6.3	11	2 000	4 000	50	4A

$$M_{2max} = 1.2 \cdot M_{n2} \quad (n_2 \cdot h = 10\ 000)$$

M₂ = 35000 Nm
311R

	i	M _{n2} [Nm]						P ₁	P _t	n ₁	n _{1max}	M _b	
		n ₂ ·h	n ₂ ·h	n ₂ ·h	n ₂ ·h	n ₂ ·h	n ₂ ·h						
	1:	10 000	25 000	50 000	100 000	500 000	1 000 000						
R2 (A)	17.7	14 800	14 300	14 300	14 300	9 600	7 800	135	75	1 800	3 800	1000	5K
	22.7	18 300	18 300	18 300	18 300	11 500	9 300	135	75	1 800	3 800	1000	5K
	27.0	21 800	21 800	21 800	21 000	12 900	10 500	135	75	1 800	3 800	1000	5K
R2 (B)	12.0	28 200	27 800	25 000	23 800	15 900	12 700	150	75	1 500	2 500	3200	6L
	15.4	35 600	33 600	31 100	30 600	18 800	15 300	150	75	1 500	2 500	3200	6L
	18.3	34 000	29 500	27 000	27 000	18 600	15 100	150	75	1 500	2 500	2600	6K
R2 (C)	16.6	39 300	29 800	23 800	19 400	11 900	9 800	150	90	1 500	2 500	3200	6L
	21.3	43 000	34 600	28 300	22 900	14 300	11 500	150	90	1 500	2 500	2600	6K
	25.3	34 000	29 500	27 000	26 000	16 000	13 000	150	90	1 500	2 500	2100	6G
R3	53.0	31 100	26 800	24 000	22 100	13 700	11 100	85	40	2 000	4 000	800	5G
	63.2	36 000	31 100	28 000	25 000	15 500	12 600	85	40	2 000	4 000	800	5G
	68.0	38 300	33 100	30 100	26 400	16 300	13 200	85	40	2 000	4 000	630	5E
	81.1	44 100	38 400	36 000	29 800	18 400	14 900	85	40	2 000	4 000	630	5E
	96.3	35 200	34 500	34 500	30 300	18 700	15 200	62	40	2 000	4 000	500	5C
	104	43 000	36 500	32 300	32 000	19 700	16 000	67	40	2 000	4 000	500	5C
	124	43 000	36 500	32 300	32 000	19 700	16 000	58	40	2 000	4 000	400	5B
	147	34 000	29 500	27 000	27 000	18 600	15 100	40	40	2 000	4 000	400	5B
R4	154	43 200	32 800	26 700	21 700	13 400	10 900	35	22	2 000	4 000	330	4H
	182	45 000	36 900	29 900	24 300	15 000	12 200	35	22	2 000	4 000	330	4H
	198	44 100	39 100	31 700	25 800	15 900	12 900	35	22	2 000	4 000	260	4F
	223	35 700	35 700	34 500	28 000	17 300	14 000	35	22	2 000	4 000	260	4F
	266	45 000	45 000	37 300	30 300	18 700	15 200	35	22	2 000	4 000	260	4F
	294	44 100	41 700	37 300	30 300	18 700	15 200	35	22	2 000	4 000	160	4D
	322	45 000	45 000	37 300	30 300	18 700	15 200	35	22	2 000	4 000	160	4D
	341	44 100	41 700	37 300	30 300	18 700	15 200	35	22	2 000	4 000	160	4D
	413	44 100	41 700	37 300	30 300	18 700	15 200	32	22	2 000	4 000	160	4D
	438	43 000	36 500	32 300	32 000	19 700	16 000	30	22	2 000	4 000	100	4D
	490	35 200	34 500	34 500	30 300	18 700	15 200	24	22	2 000	4 000	100	4B
	520	43 000	36 500	32 300	32 000	19 700	16 000	24	22	2 000	4 000	100	4B
	629	43 000	36 500	32 300	32 000	19 700	16 000	21	22	2 000	4 000	100	4B
	746	34 000	29 500	27 000	27 000	18 600	15 100	16	22	2 000	4 000	100	4B

$$M_{2max} = 1.2 \cdot M_{n2} \quad (n_2 \cdot h = 10\,000)$$

Nota: i contrassegni (A) (B) (C) sulla stessa grandezza, indicano riduzioni angolari di dimensioni differenti: vedere le pagine dimensionali.

Note: Letters (A) (B) (C) near size indication identify different angle reduction dimensions. See pages relevant to dimensions.

Hinweis: Die Kennzeichnungen (A) (B) (C) an der gleichen Baugröße weisen auf die Winkelreduzierung in unterschiedlichen Maßen hin: siehe Seiten mit Maßtabellen

Remarque : les indications (A) (B) (C) sur la même taille indique des réductions angulaires de dimensions différentes. Se reporter aux pages des dimensions.

311L

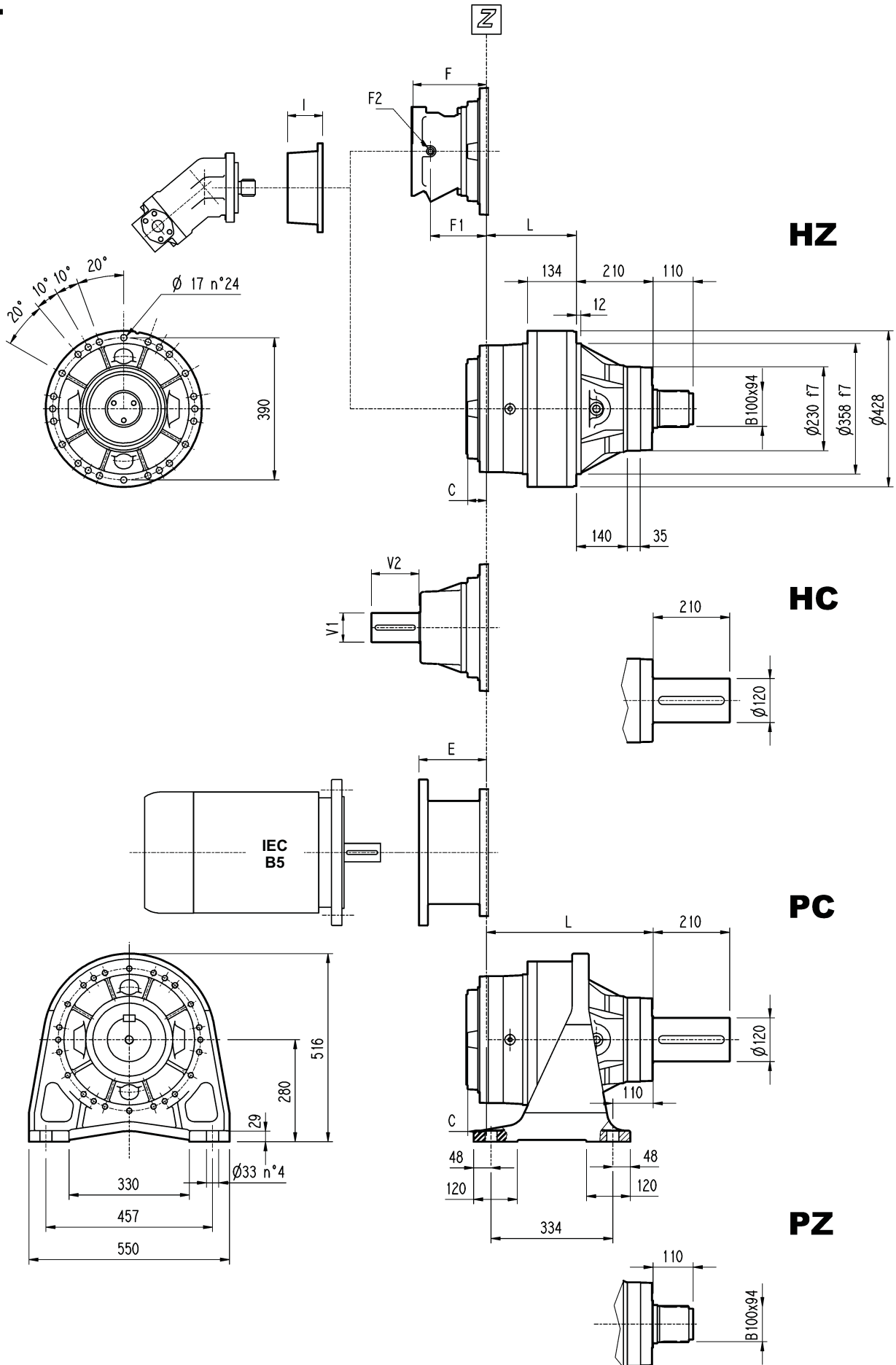

311L

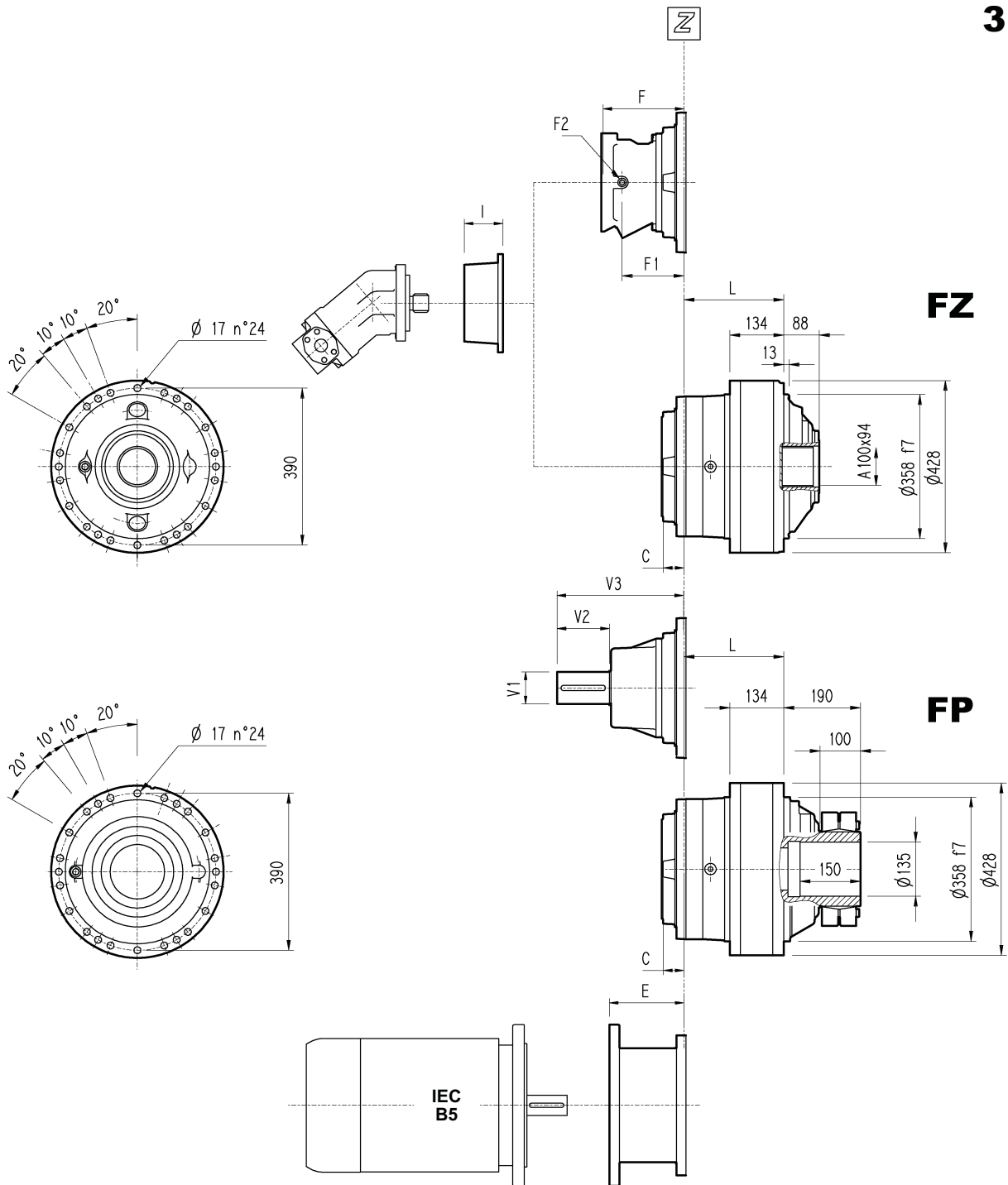

VERSIONE FP FP VERSION VERSION FP VERSION FP	COPPIA MAX. TRASMISSIBILE MAX. TRANSMISSIBLE TORQUE MAX. ÜBERTR. MOMENT COUPLE MAX. TRANSMISSIBLE	54 000 Nm
---	--	------------------

	L				Kg				C	Entrata Input Antrieb Entrée	I	F	F1	F2	Tipo Type Typ Type	Entrata Input Antrieb Entrée	Kg
	HZ HC	PC PZ	FZ	FP	HZ HC	PC PZ	FZ	FP									
311 L1	115	325	115	115	180	250	160	170	81	D	191						
311 L2	248	458	248	248	225	295	205	215	51	B		201	153	1/4 G	6	B	28
311 L3	337	547	337	337	237	307	217	227	37	A		145	95	1/4 G	5	A	16
311 L4	402	612	402	402	244	314	224	234	37	A		105	65	1/4 G	4	A	10

	V1	V2	V3	Kg	V1	V2	V3	Kg	E													
									IEC 71	IEC 80	IEC 90	IEC 100	IEC 112	IEC 132	IEC 160	IEC 180	IEC 200	IEC 225	IEC 250			
311 L1	80	130	348	55																		
311 L2	80	130	315	35	60	105	313	28								195	186	216	215			
311 L3	48	82	239	15										114	144	144	174					
311 L4	24	36	137.5	6	38	58	158	7	65	84	84	94	94	114	144							

311R

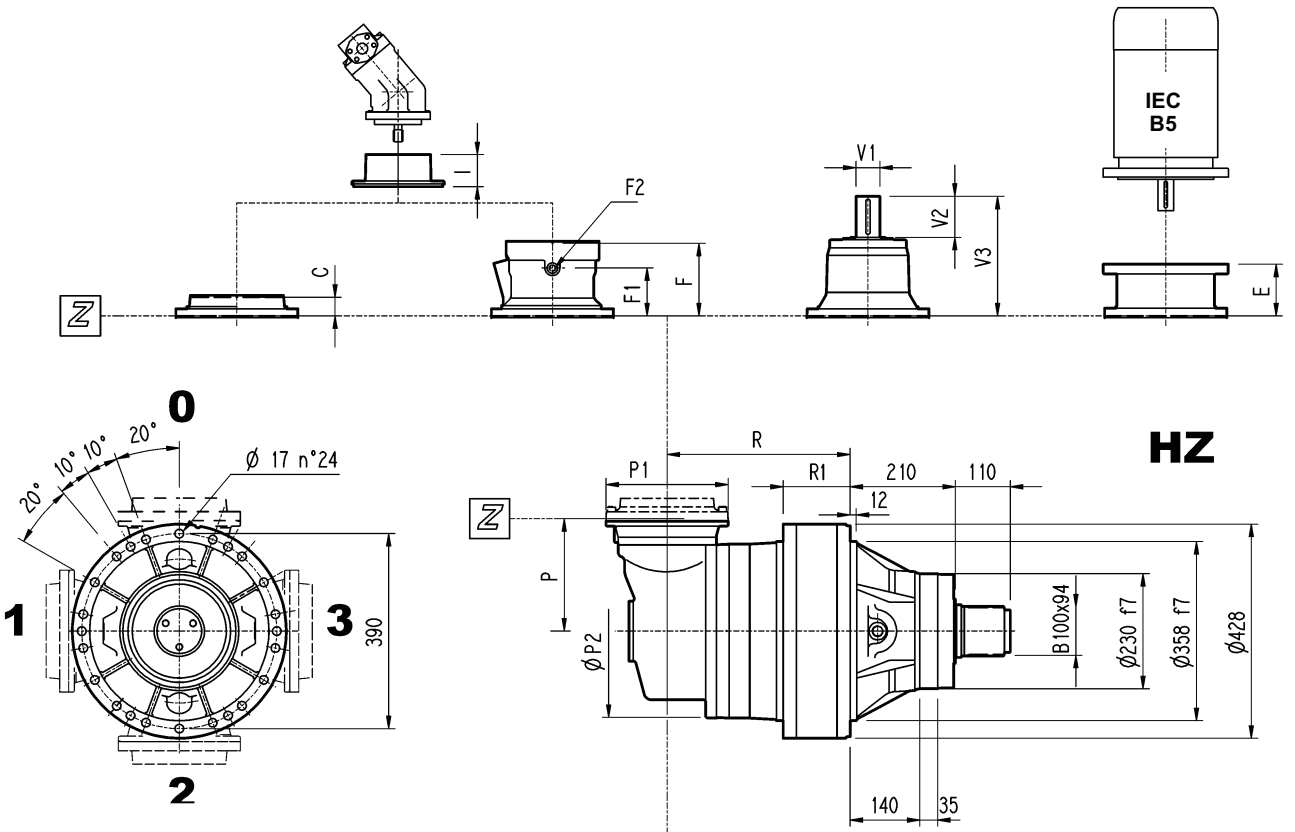

Solo per esecuzione:
Only for execution:

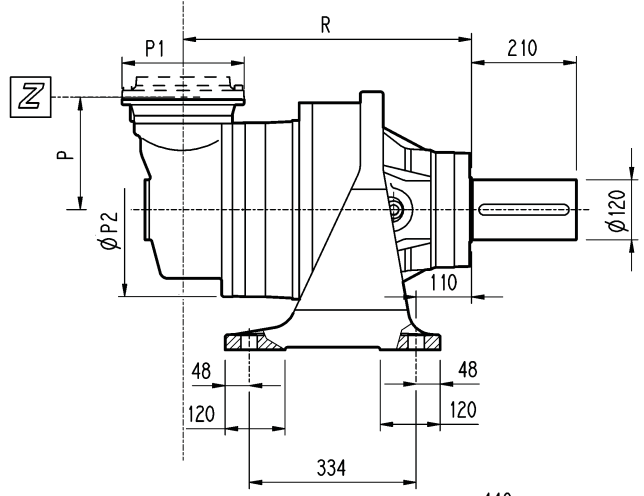
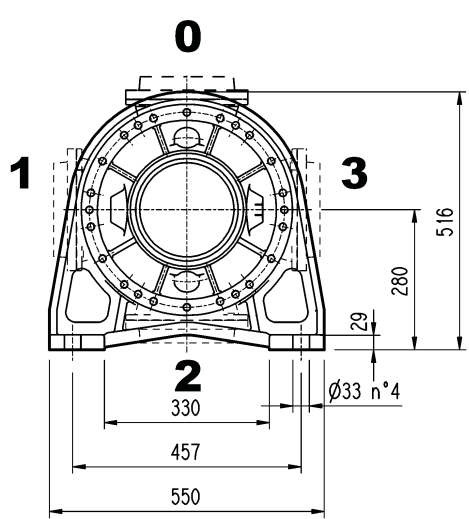
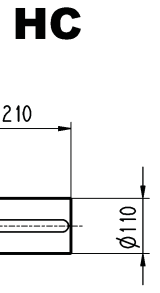
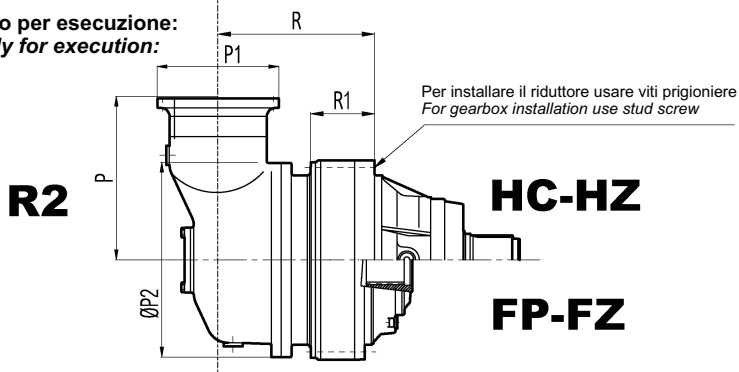

311R

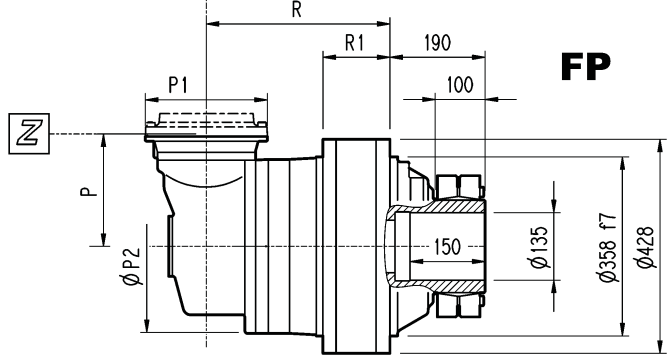
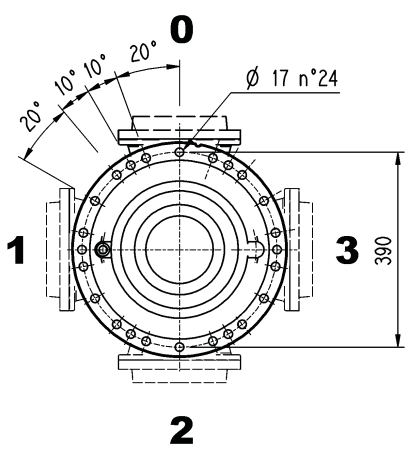
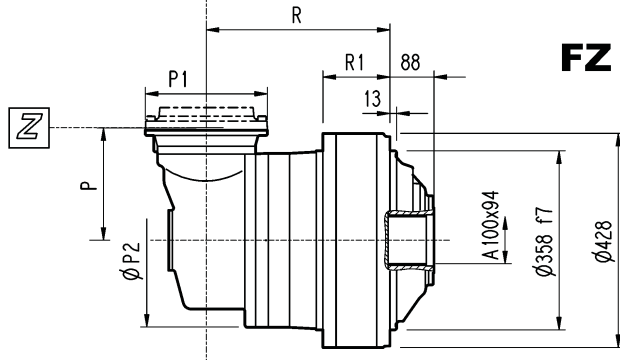
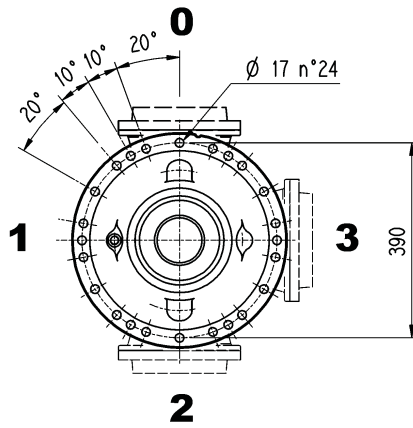
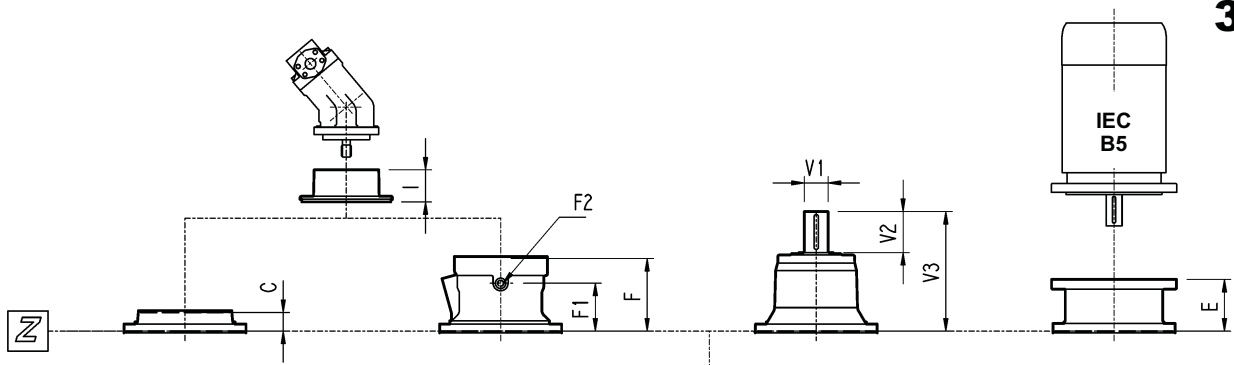

VERSIONE FP FP VERSION VERSION FP VERSION FP	COPPIA MAX. TRASMISSIBILE MAX. TRANSMISSIBLE TORQUE MAX. ÜBERTR. MOMENT COUPLE MAX. TRANSMISSIBLE	54 000 Nm
---	--	------------------

	R				R1				P	P1	P2	Kg				C	Entrata Input Antrieb Entrée	I	F	F1	F2	Tipo Type Typ Type	Entrat a Input Antrieb Entrée	Kg
	HZ HC	PC PZ	FZ	FP	HZ HC	PC PZ	FZ	FP				HZ HC	PC PZ	FZ	FP									
311 R2 (B)	340	550	340	340	154	-	154	154	345	292	400	310	380	290	300	45	B	195	147	1/4 G	6	B	28	
311 R2 (C)	340	550	340	340	154	-	154	154	390	292	480	320	390	300	310	45	B	195	147	1/4 G	6	B	28	
311 R2 (A)	340	550	340	340	154	-	154	154	330	245	390	290	360	270	280	37	A	145	95	1/4 G	5	A	16	
311 R3	367	577	367	367	134	-	134	134	225	245	375	275	345	255	265	37	A	145	95	1/4 G	5	A	16	
311 R4	429	639	429	429	134	-	134	134	140	186	244	257	327	237	247	37	A	105	65	1/4 G	4	A	10	

	V1	V2	V3	Kg	V1	V2	V3	Kg	E													
	IEC 71	IEC 80	IEC 90		IEC 100	IEC 112	IEC 132		IEC 160	IEC 180	IEC 200	IEC 225	IEC 250									
311 R2 (B)	60	105	307	23																		
311 R2 (C)	60	105	307	23																		
311 R2 (A)	48	82	239	15												114	144	144	174			
311 R3	48	82	239	15												114	144	144	174			
311 R4	24	36	137.5	6	38	58	158	7	65	84	84	94	94	114	144							

311L - 311R

HC

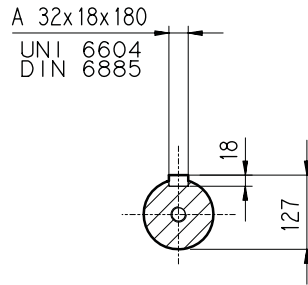
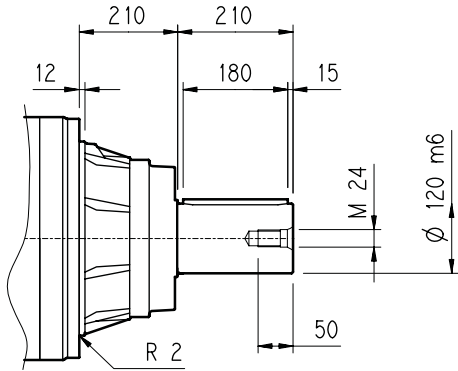

PC

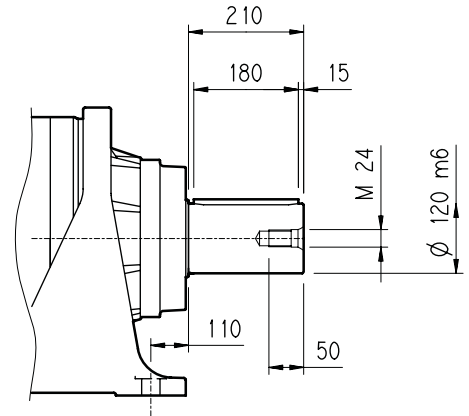

HZ

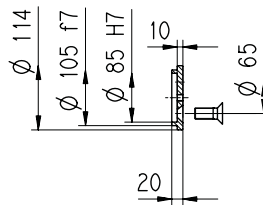
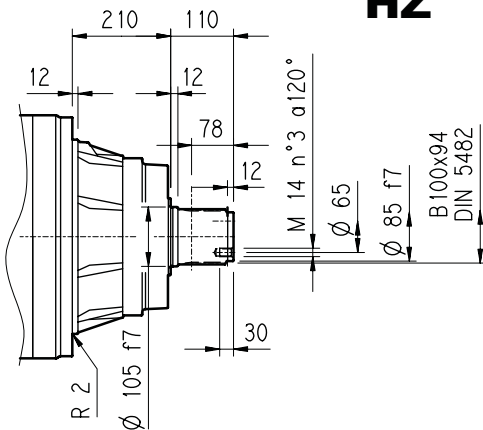

FZ

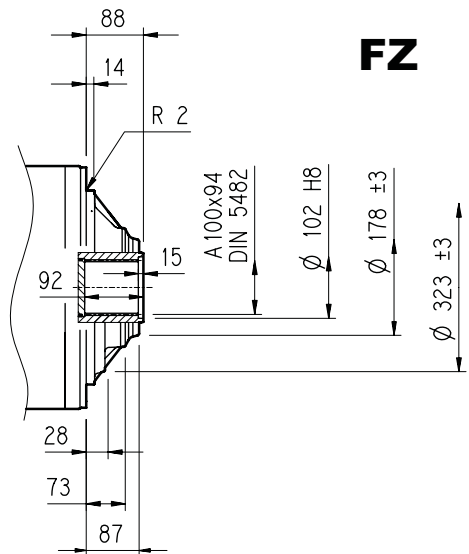

FP

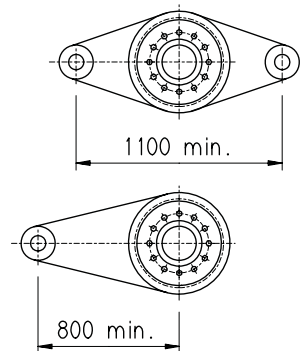
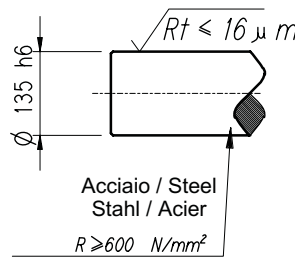
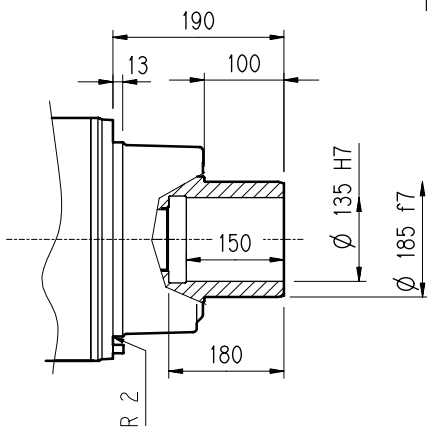

VERSIONE FP	COPPIA MAX. TRASMISSIBILE	54 000 Nm
FP VERSION	MAX. TRANSMISSIBLE TORQUE	
VERSION FP	MAX. ÜBERTR. MOMENT	
VERSION FP	COUPLE MAX. TRASMISSIBILE	

311L - 311R

Alberi veloci / Input shaft
Antriebswellen / Arbres d'entrée

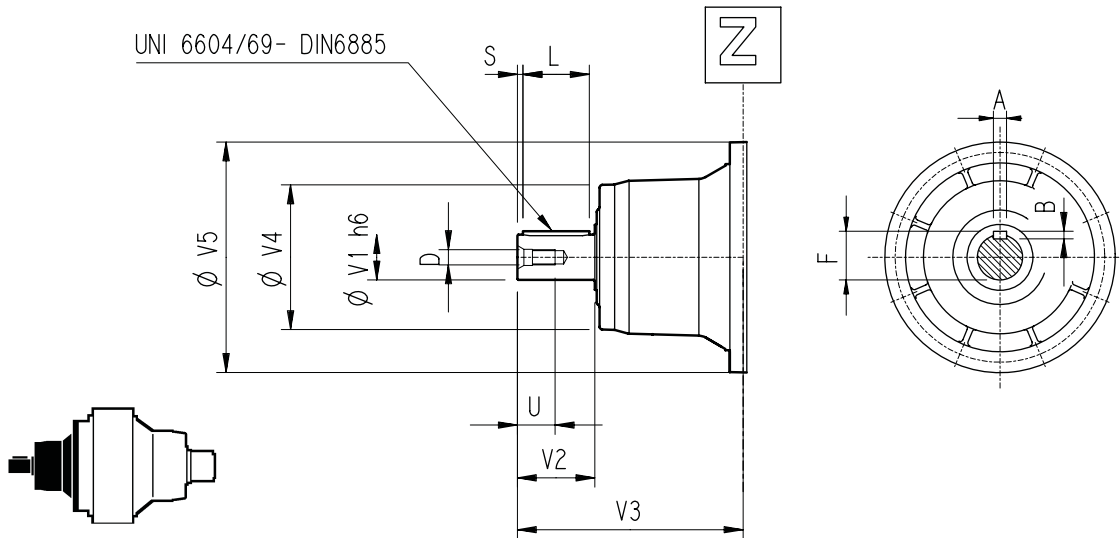

	CODE	V1	V2	V3	V4	V5	A	B	F	L	S	D	U
311 L1	V11B	80	130	348	200	428	22	14	85	110	10	M16	36
311 L2	V07B	80	130	315	200	345	22	14	85	110	10	M16	36
	V07A	60	105	313	155	345	18	11	64	90	7.5	M16	36
311 L3	V05B	48	82	239	155	245	14	9	51.5	70	6	M16	36
311 L4	V01A	24	36	137.5	120	186	8	7	27	30	3	M8	19
	V01B	38	58	158	120	186	10	8	41	50	4	M12	28
311 R2 (A)-R3	V05B	48	82	239	155	245	14	9	51.5	70	6	M16	36
311 R2 (B) (C)	V06B	60	105	307	155	292	18	11	64	90	7.5	M16	36
311 R4	V01A	24	36	137.5	120	186	8	7	27	30	3	M8	19
	V01B	38	58	158	120	186	10	8	41	50	4	M12	28

Dimensioni d'entrata senza predisposizione motore
Input dimension without motor adaptor
Maße für den Antrieb ohne Motoradapter
Dimensions d'entrée sans prédisposition moteur

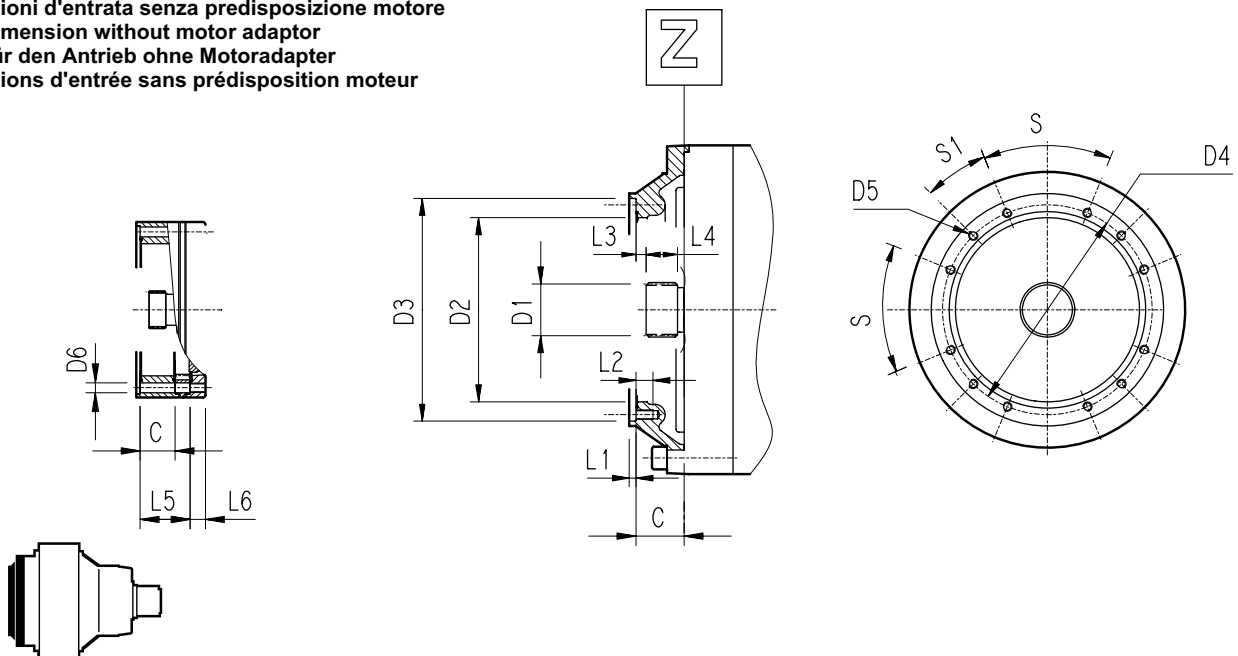

	C	D1	D2	D3	D4	D5	D6	L1	L2	L3	L4	L5	L6	S	S1	Entrata Input Antrieb Entrée
311 L1	81	80x74 DIN 5482	270	335 H7	314	M16 n°8	/	5	30	8.5	40	/	/	60°	30°	D
311 L2	51	58x53 DIN 5482	195	236 H7	222	M10 n°12	/	4	18	11	22	/	/	45°	22.5°	B
311 L3	37	40x36 DIN 5482	140	178 H7	165	M10 n°8	0	4	18	9	18	0	0	45°	45°	A
311 L4	37	40x36 DIN 5482	140	178 H7	165	M10 n°8	11	4	0	9	18	65	18	45°	45°	A
311 R2 (A)-R3	37	40x36 DIN 5482	140	178 H7	165	M10 n°8	11	4	18	9	18	0	0	45°	45°	A
311 R2 (B) (C)	45	58x53 DIN 5482	195	236 H7	222	M10 n°12	/	4	18	11	22	/	/	45°	22.5°	B
311 R4	37	40x36 DIN 5482	140	178 H7	165	M10 n°8	11	4	/	9	18	37	18	45°	45°	A

311L - 311R

Carichi radiali ed assiali ammissibili sull'albero lento per un valore di $Fh_2 : n_2 \cdot h = 10\ 000$

Permissible radial and axial loads on output shaft with $Fh_2 : n_2 \cdot h = 10\ 000$

An der Ausgangswelle zulässige Radiallasten und Axialkräfte für einen Wert von $Fh_2 : n_2 \cdot h = 10\ 000$

Charges radiales et axiales admises sur l'arbre lent pour une valeur de $Fh_2 : n_2 \cdot h = 10\ 000$

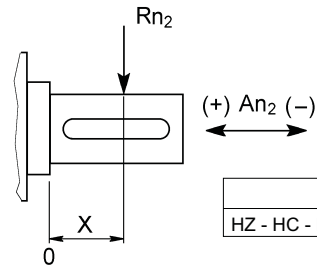
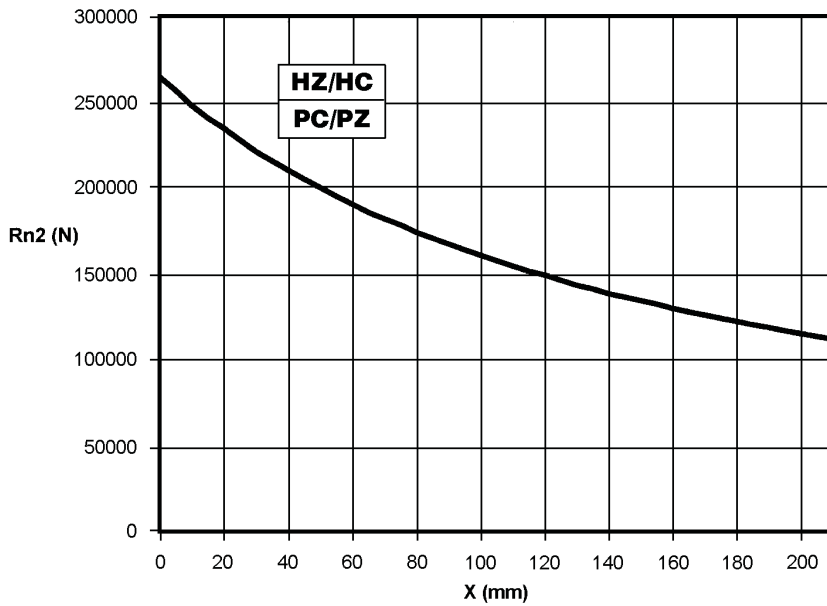

	An ₂ (+)	An ₂ (-)
HZ - HC - PC - PZ	200 000	140 000

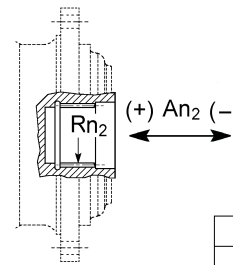

	Rn ₂	An ₂ (+/-)
FZ	65 000	60 000

Fattore fh_2 correttivo per carichi sugli alberi Load corrective factor fh_2 on shafts Korrektionsfaktor fh_2 für wellenbelastungen Facteur de correction fh_2 pour charges sur les arbres	$Fh_2 = n_2 \cdot h$						
	FZ	10 000	25 000	50 000	100 000	500 000	1 000 000
fh_2	FZ	1	0.74	0.58	0.46	0.27	0.21
	HZ - HC - PC - PZ	1	0.76	0.61	0.50	0.31	0.25

Carichi radiali ammissibili sull'albero veloce per un valore di $Fh_1 : n_1 \cdot h = 250\ 000$

Permissible radial loads on input shaft with $Fh_1 : n_1 \cdot h = 250\ 000$

An der Antriebswelle zulässige Radiallasten für einen Wert von $Fh_1 : n_1 \cdot h = 250\ 000$

Charges radiales admises sur l'arbre d'entrée pour une valeur de $Fh_1 : n_1 \cdot h = 250\ 000$

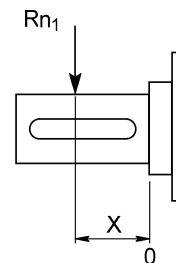
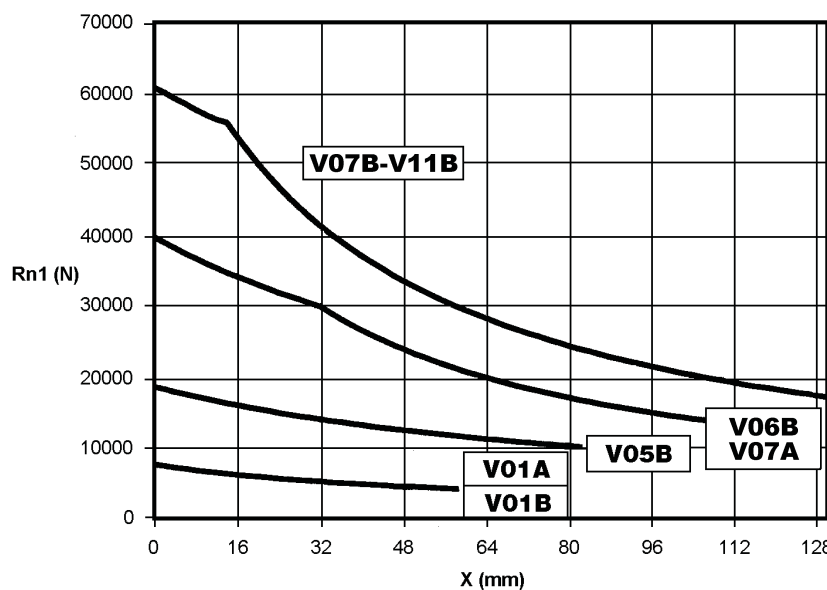

Fattore fh_1 correttivo per carichi sugli alberi Load corrective factor fh_1 on shafts Korrektionsfaktor fh_1 für wellenbelastungen Facteur de correction fh_1 pour charges sur les arbres	$Fh_1 = n_1 \cdot h$						
	250 000	500 000	1 000 000	2 000 000	5 000 000	10 000 000	
fh_1	1	0.79	0.63	0.50	0.37	0.29	