





310L

M₂ = 25000 Nm

	i	M _{n2} [Nm]						P ₁ [kW]	P _t [kW]	n ₁ [min ⁻¹]	n _{1max} [min ⁻¹]	M _b [Nm]	
		n ₂ ·h 10 000	n ₂ ·h 25 000	n ₂ ·h 50 000	n ₂ ·h 100 000	n ₂ ·h 500 000	n ₂ ·h 1 000 000						
L1	4.09	30 000	30 000	26 200	21 300	13 100	10 700	150	35	1 000	1 500		
	5.25	29 500	25 400	22 700	20 500	12 700	10 300	150	35	1 000	1 500		
	6.23	26 000	21 200	18 100	17 800	12 600	10 200	150	35	1 000	1 500		
L2	14.7	30 000	29 800	26 200	21 300	13 100	10 700	75	22	1 500	3 000	2 100	6G
	17.4	30 000	30 000	26 200	21 300	13 100	10 700	75	22	1 500	3 000	2 100	6G
	21.8	30 000	30 000	26 200	21 300	13 100	10 700	75	22	1 500	3 000	1 500	6E
	25.4	26 100	25 800	25 800	21 300	13 100	10 700	75	22	1 500	3 000	1 500	6E
	28.0	29 500	25 400	22 700	20 500	12 700	10 300	75	22	1 500	3 000	1 500	6E
	30.7	21 800	21 800	21 800	19 900	12 300	10 000	75	22	1 500	3 000	1 100	6C
	32.6	29 500	25 400	22 700	20 500	12 700	10 300	75	22	1 500	3 000	1 100	6C
	38.6	26 000	21 200	18 100	17 800	12 600	10 200	75	22	1 500	3 000	850	6B
	46.7	26 000	21 200	18 100	17 800	12 600	10 200	71	22	1 500	3 000	850	6B
L3	53.0	29 100	29 100	26 200	21 300	13 100	10 700	40	18	1 800	3 800	630	5E
	62.6	30 000	29 800	26 200	21 300	13 100	10 700	40	18	1 800	3 800	630	5E
	73.9	30 000	30 000	26 200	21 300	13 100	10 700	40	18	1 800	3 800	500	5C
	80.3	29 500	25 400	22 700	20 500	12 700	10 300	40	18	1 800	3 800	400	5B
	91.3	24 900	24 900	21 400	17 400	10 700	8 700	40	18	1 800	3 800	400	5B
	101	29 500	25 400	22 700	20 500	12 700	10 300	40	18	1 800	3 800	400	5B
	110	22 900	22 900	22 500	18 300	11 300	9 200	36	18	1 800	3 800	400	5B
	119	29 500	25 400	22 700	20 500	12 700	10 300	40	18	1 800	3 800	400	5B
	130	27 000	27 000	25 300	20 500	12 700	10 300	36	18	1 800	3 800	400	5B
	142	29 300	25 400	22 700	20 500	12 700	10 300	35	18	1 800	3 800	400	5B
	164	30 000	30 000	26 200	21 300	13 100	10 700	32	18	1 800	3 800	400	5B
	177	26 000	21 200	18 100	17 800	12 600	10 200	26	18	1 800	3 800	400	5B
	202	29 500	25 400	22 700	20 500	12 700	10 300	26	18	1 800	3 800	400	5B
	230	21 800	21 800	21 800	19 900	12 300	10 000	17.3	18	1 800	3 800	400	5B
	249	26 000	21 200	18 100	17 800	12 600	10 200	20	18	1 800	3 800	400	5B
295	28 000	25 400	22 700	20 500	12 700	10 300	17.3	18	1 800	3 800	400	5B	
350	26 000	21 200	18 100	17 800	12 600	10 200	14.7	18	1 800	3 800	400	5B	
L4	389	24 900	24 900	21 400	17 400	10 700	8 700	18.9	11	2 000	4 000	100	4B
	451	30 000	25 700	20 900	16 900	10 500	8 500	19.7	11	2 000	4 000	100	4B
	507	29 500	25 400	22 700	20 500	12 700	10 300	17.5	11	2 000	4 000	100	4B
	556	27 000	27 000	25 300	20 500	12 700	10 300	14.4	11	2 000	4 000	50	4A
	637	22 900	22 900	22 500	18 300	11 300	9 200	10.6	11	2 000	4 000	50	4A
	726	29 500	25 400	22 700	20 500	12 700	10 300	12.2	11	2 000	4 000	50	4A
	818	29 300	25 400	22 700	20 500	12 700	10 300	10.6	11	2 000	4 000	50	4A
	939	27 000	27 000	25 300	20 500	12 700	10 300	8.5	11	2 000	4 000	50	4A
	1 021	29 300	25 400	22 700	20 500	12 700	10 300	8.5	11	2 000	4 000	50	4A
	1 164	29 500	25 400	22 700	20 500	12 700	10 300	7.6	11	2 000	4 000	50	4A
	1 259	28 000	25 400	22 700	20 500	12 700	10 300	7.0	11	2 000	4 000	50	4A
	1 438	26 000	21 200	18 100	17 800	12 600	10 200	6.2	11	2 000	4 000	50	4A
	1 657	21 800	21 800	21 800	19 900	12 300	10 000	5.4	11	2 000	4 000	50	4A
	1 794	26 000	21 200	18 100	17 800	12 600	10 200	4.9	11	2 000	4 000	50	4A
	2 022	26 000	21 200	18 100	17 800	12 600	10 200	4.4	11	2 000	4 000	50	4A
2 523	26 000	21 200	18 100	17 800	12 600	10 200	3.5	11	2 000	4 000	50	4A	

M_{2max} = 1.2 · M_{n2} (n₂ · h = 10 000)

M₂ = 25000 Nm
310R

	i	M _{n2} [Nm]						P ₁ [kW]	P _t [kW]	n ₁ [min ⁻¹]	n _{1max} [min ⁻¹]	M _b [Nm]	
		n ₂ ·h 10 000	n ₂ ·h 25 000	n ₂ ·h 50 000	n ₂ ·h 100 000	n ₂ ·h 500 000	n ₂ ·h 1 000 000						
R2 (A)	17.7	14 800	14 300	14 300	14 300	9 500	7 700	130	55	1 800	3 800	1 000	5K
	22.7	18 300	18 300	18 300	18 300	12 700	8 700	130	55	1 800	3 800	1 000	5K
	27.0	21 800	21 200	18 700	17 800	12 600	9 100	130	55	1 800	3 800	1 000	5K
R2 (B)	12.0	28 200	27 800	25 000	21 300	13 100	10 700	130	55	1 500	2 500	3 200	6L
	15.4	29 500	25 400	22 700	20 500	12 700	10 300	130	55	1 500	2 500	2 600	6K
	18.3	26 000	21 200	18 100	17 800	12 600	10 200	130	55	1 500	2 500	2 100	6G
R3	37.7	14 800	12 600	10 300	8 300	5 100	4 150	35	20	1 800	3 800	440	4L
	44.6	17 100	14 200	11 500	9 400	5 800	4 700	35	20	1 800	3 800	440	4L
	55.9	20 700	16 600	13 500	11 000	6 800	5 500	35	20	1 800	3 800	400	4K
	65.0	23 500	18 500	15 000	12 200	7 500	6 100	35	20	1 800	3 800	400	4K
	71.8	25 500	19 800	16 100	13 100	8 100	6 500	35	20	1 800	3 800	400	4K
	78.6	21 800	21 100	17 100	13 900	8 600	7 000	35	20	1 800	3 800	330	4H
	83.4	28 900	22 000	17 900	14 500	9 000	7 300	35	20	1 800	3 800	400	4K
	99.0	26 000	21 200	18 100	16 400	10 100	8 200	35	20	1 800	3 800	330	4H
	120	26 000	21 200	18 100	17 800	11 500	9 400	35	20	1 800	3 800	260	4F
R4	136	29 100	29 100	24 400	19 800	12 200	9 900	35	14	2 000	4 000	260	4F
	160	30 000	29 800	26 200	21 300	13 100	10 700	35	14	2 000	4 000	260	4F
	189	30 000	30 000	26 200	21 300	13 100	10 700	35	14	2 000	4 000	260	4F
	206	29 500	25 400	22 700	20 500	12 700	10 300	35	14	2 000	4 000	160	4D
	234	24 900	24 900	21 400	17 400	10 700	8 700	32	14	2 000	4 000	160	4D
	258	29 500	25 400	22 700	20 500	12 700	10 300	34	14	2 000	4 000	160	4D
	283	22 900	22 900	22 500	18 300	11 300	9 200	24	14	2 000	4 000	100	4B
	305	29 500	25 400	22 700	20 500	12 700	10 300	29	14	2 000	4 000	100	4B
	334	27 000	27 000	25 300	20 500	12 700	10 300	24	14	2 000	4 000	100	4B
	363	29 300	25 400	22 700	20 500	12 700	10 300	24	14	2 000	4 000	100	4B
	419	30 000	30 000	26 200	21 300	13 100	10 700	21	14	2 000	4 000	100	4B
	454	26 000	21 200	18 100	17 800	12 600	10 200	19.4	14	2 000	4 000	100	4B
	517	29 500	25 400	22 700	20 500	12 700	10 300	17.2	14	2 000	4 000	100	4B
	590	21 800	21 800	21 800	19 900	12 300	10 000	12.6	14	2 000	4 000	50	4A
	639	26 000	21 200	18 100	17 800	12 600	10 200	13.9	14	2 000	4 000	50	4A
	757	28 000	25 400	22 700	20 500	12 700	10 300	11.7	14	2 000	4 000	50	4A
898	26 000	21 200	18 100	17 800	12 600	10 200	9.9	14	2 000	4 000	50	4A	

$$M_{2max} = 1.2 \cdot M_{n2} \quad (n_2 \cdot h = 10\,000)$$

Nota: i contrassegni (A) (B) (C) sulla stessa grandezza, indicano riduzioni angolari di dimensioni differenti: vedere le pagine dimensionali.

Note: Letters (A) (B) (C) near size indication identify different angle reduction dimensions. See pages relevant to dimensions.

Hinweis: Die Kennzeichnungen (A) (B) (C) an der gleichen Baugröße weisen auf die Winkelreduzierung in unterschiedlichen Maßen hin: siehe Seiten mit Maßtabellen

Remarque : les indications (A) (B) (C) sur la même taille indique des réductions angulaires de dimensions différentes. Se reporter aux pages des dimensions.

310L

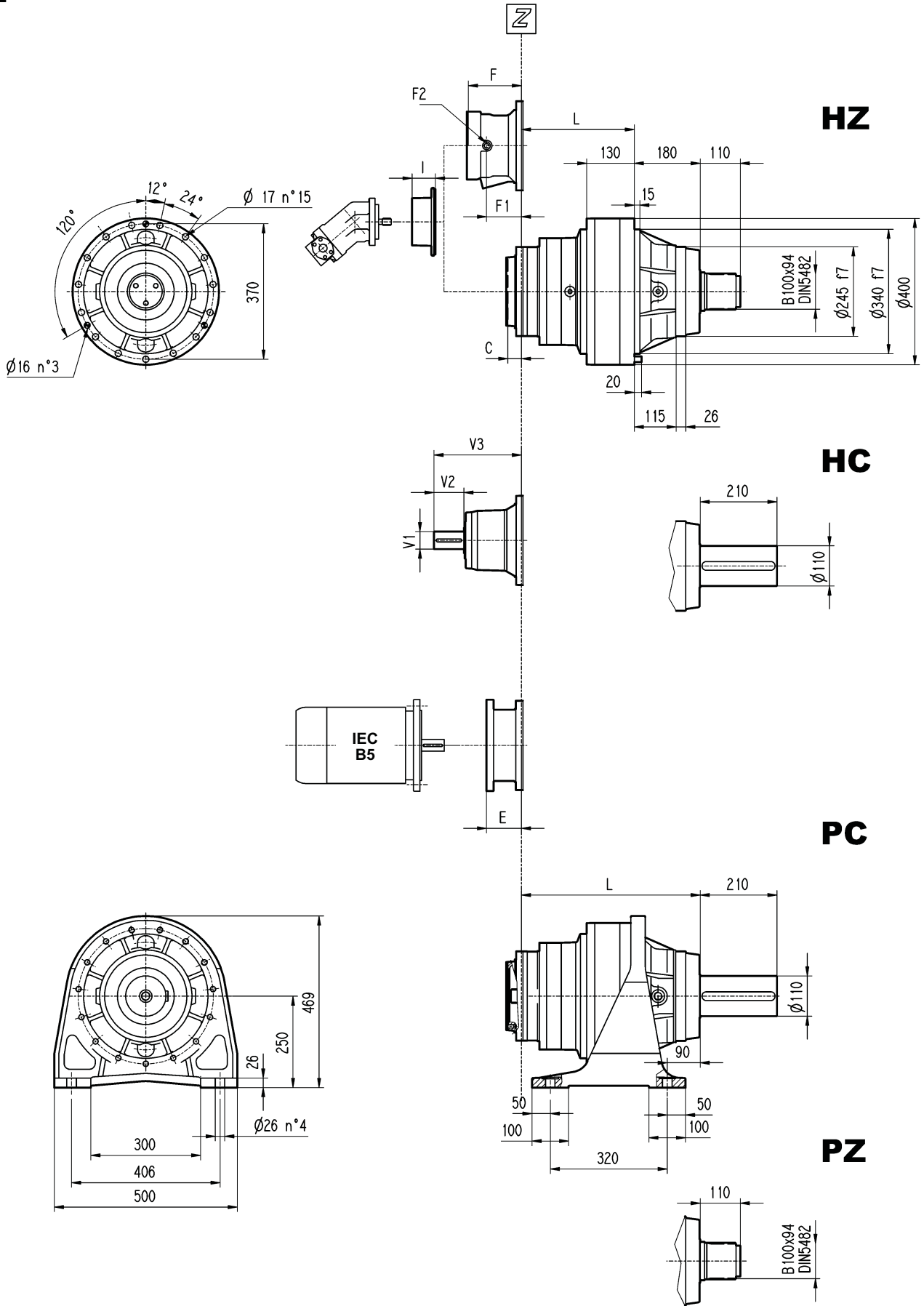

310L

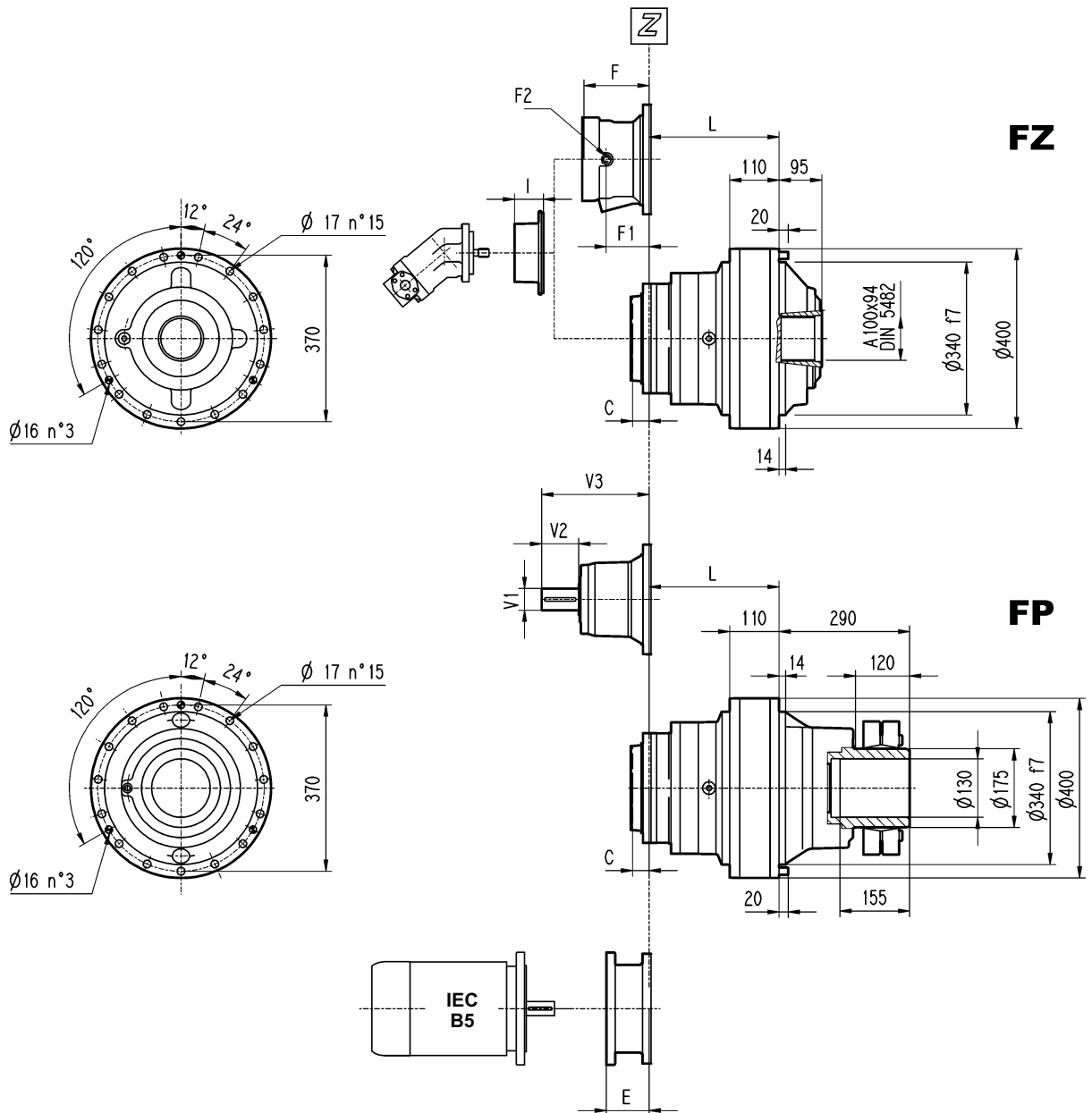

VERSIONE FP FP VERSION VERSION FP VERSION FP	COPPIA MAX. TRASMISSIBILE MAX. TRANSMISSIBLE TORQUE MAX. ÜBERTR. MOMENT COUPLE MAX. TRANSMISSIBLE	36 000 Nm
---	--	------------------

	L				Kg				C	Entrata Input Antrieb Entrée	I	F	F1	F2	Tipo Type Typ Type	Entrata Input Antrieb Entrée	Kg
	HZ HC	PC PZ	FZ	FP	HZ HC	PC PZ	FZ	FP									
310 L1	108	288	88	88	135	155	110	115	88	C							
310 L2	244	424	224	224	165	185	140	145	45	B	195	147	1/4 G	6	B	28	
310 L3	309	489	289	289	174	194	149	154	37	A	145	95	1/4 G	5	A	16	
310 L4	362	542	342	342	178	198	153	158	37	A	191	105	65	1/4 G	4	A	10

	V1	V2	V3	Kg	V1	V2	V3	Kg	E										
									IEC 71	IEC 80	IEC 90	IEC 100	IEC 112	IEC 132	IEC 160	IEC 180	IEC 200	IEC 225	IEC 250
310 L1	80	130	377	50													271	301	281
310 L2	60	105	307	23												152	182	212	193
310 L3	48	82	239	15									114	144	144				
310 L4	24	36	137.5	6	38	58	158	7	65	84	84	94	94	114	144				

310R

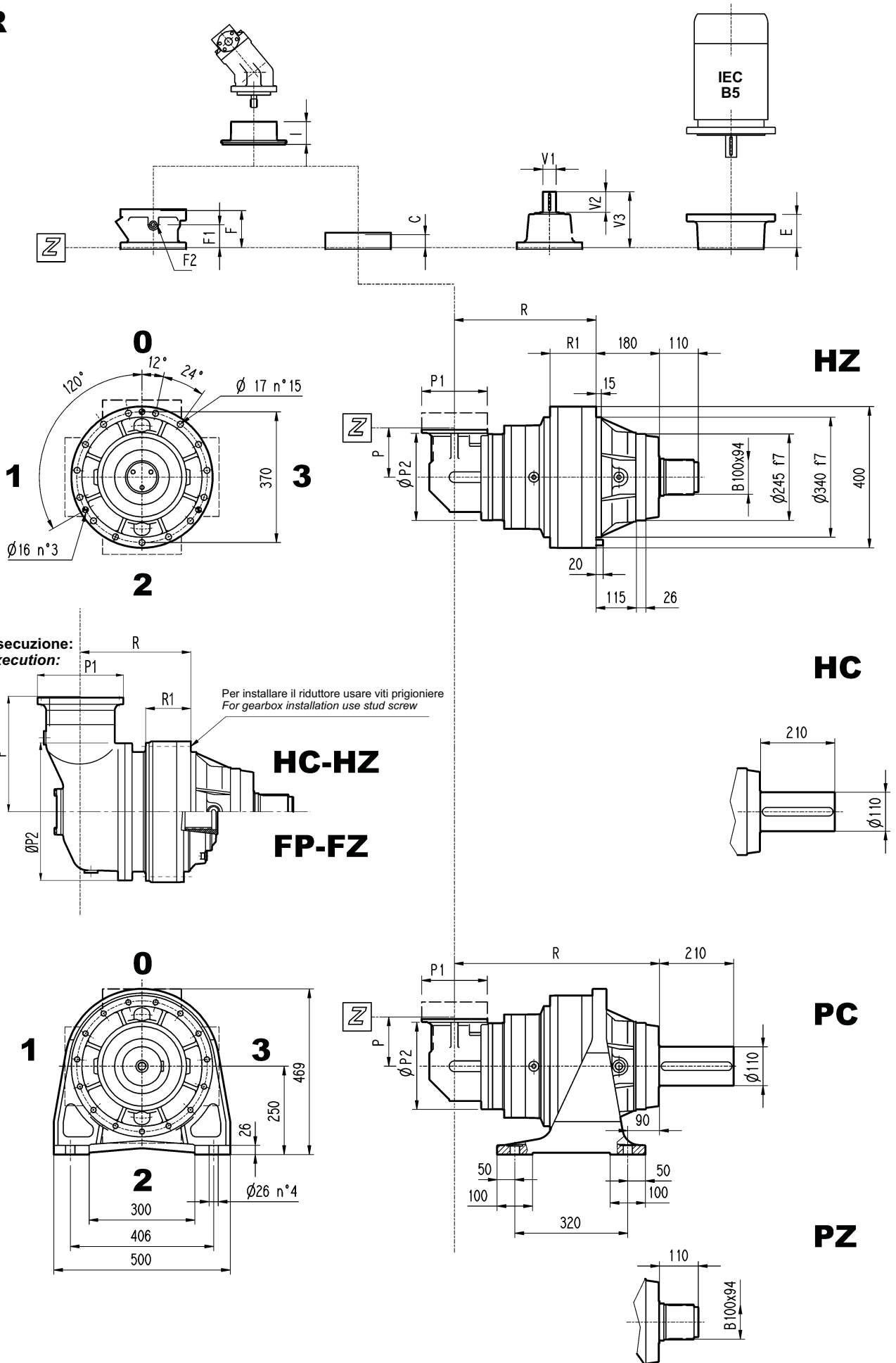

310R

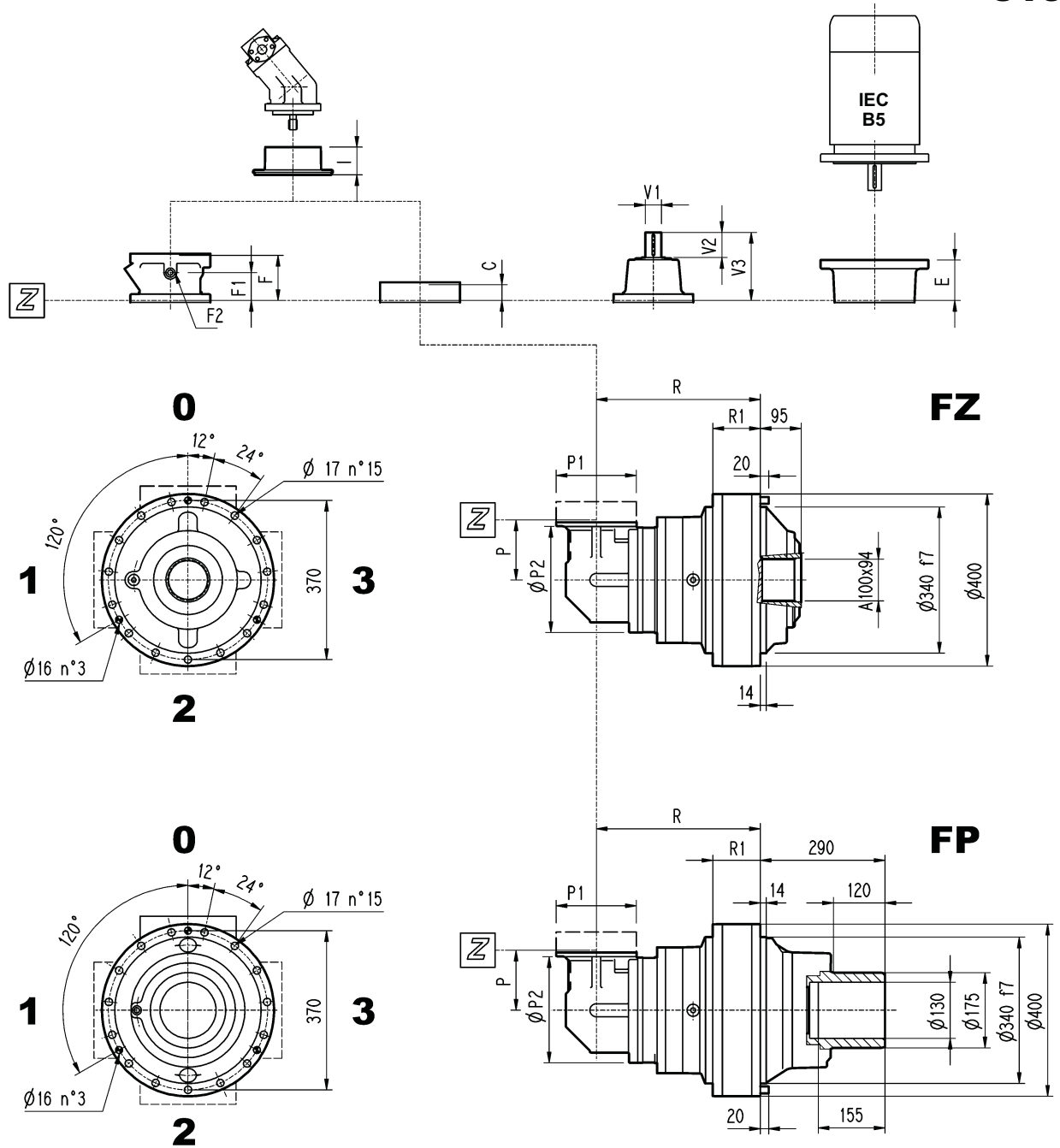

VERSIONE FP FP VERSION VERSION FP VERSION FP	COPPIA MAX. TRASMISSIBILE MAX. TRANSMISSIBLE TORQUE MAX. ÜBERTR. MOMENT COUPLE MAX. TRANSMISSIBLE	36 000 Nm
---	--	------------------

	R				R1				P	P1	P2	Kg				C	Entrata Input Antrieb Entrée	I	F	F1	F2	Tipo Type Typ Type	Entrata Input Antrieb Entrée	Kg
	HZ HC	PC PZ	FZ	FP	HZ HC	PC PZ	FZ	FP				HZ HC	PC PZ	FZ	FP									
310 R2 (B)	315	495	295	295	130	-	110	110	345	292	400	260	280	240	250	45	B	195	147	1/4 G	6	B	28	
310 R2 (A)	315	495	295	295	130	-	110	110	330	245	345	240	260	220	230	37	A	145	95	1/4 G	5	A	16	
310 R3	381	561	361	361	130	-	110	110	140	186	244	189	209	164	169	37	A	105	65	1/4 G	4	A	10	
310 R4	401	581	381	381	130	-	110	110	140	186	244	194	214	169	174	37	A	105	65	1/4 G	4	A	10	

	V1	V2	V3	Kg	V1	V2	V3	Kg	E													
									IEC 63	IEC 71	IEC 80	IEC 90	IEC 100	IEC 112	IEC 132	IEC 160	IEC 180	IEC 200	IEC 225			
310 R2 (B)	60	105	307	23																		
310 R2 (A)	48	82	239	15													114	144	144	174	174	
310 R3	24	36	137.5	6	38	58	158	7		65	84	84	94	94	114	144						
310 R4	24	36	137.5	6	38	58	158	7		65	84	84	94	94	114	144						

310L - 310R

HC

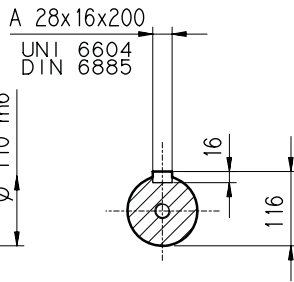
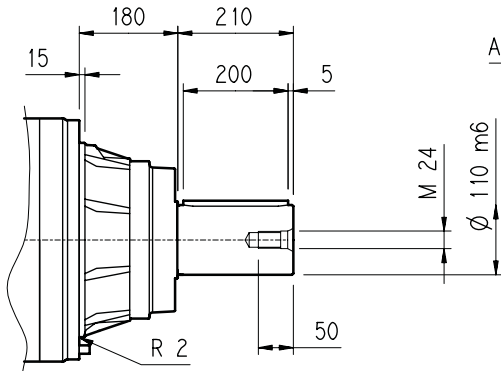

PC

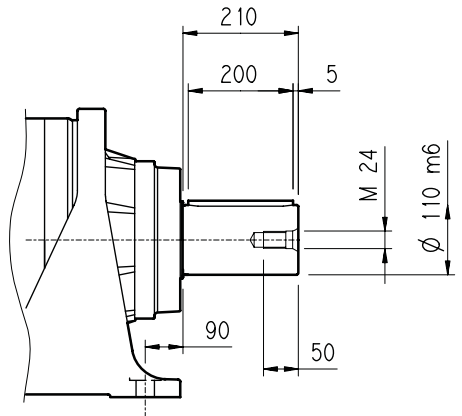

HZ

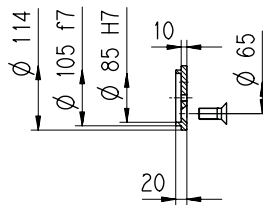
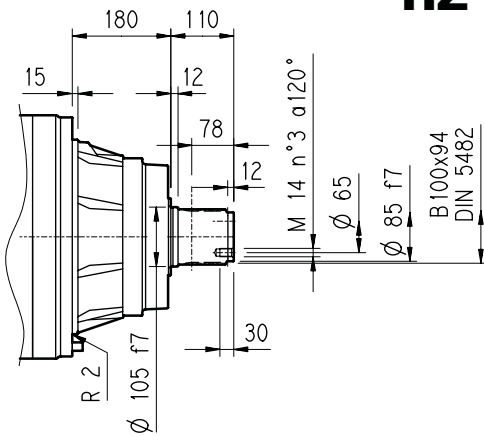

FZ

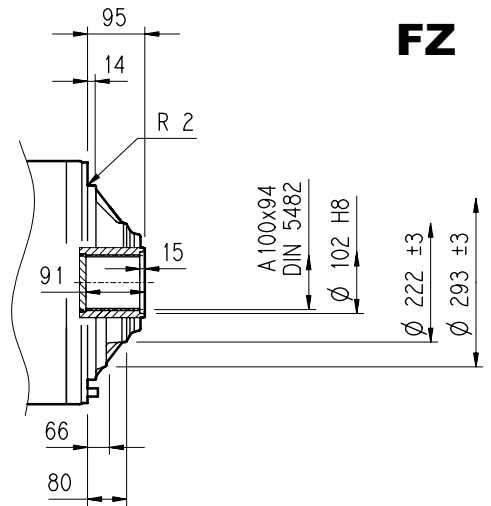

FP

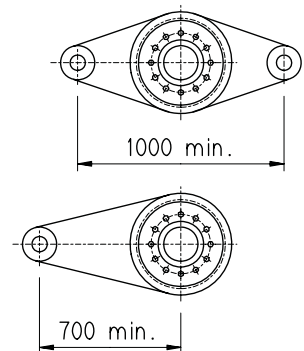
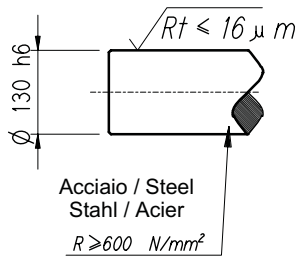
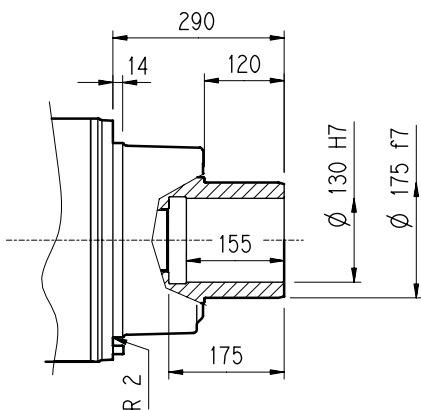

VERSIONE FP	COPPIA MAX. TRASMISSIBILE	36 000 Nm
FP VERSION	MAX. TRASMISSIBILE TORQUE	
VERSION FP	MAX. ÜBERTR. MOMENT	
VERSION FP	COUPLE MAX. TRASMISSIBILE	

Flangia / Flange
Flansch / Brides

310L - 310R

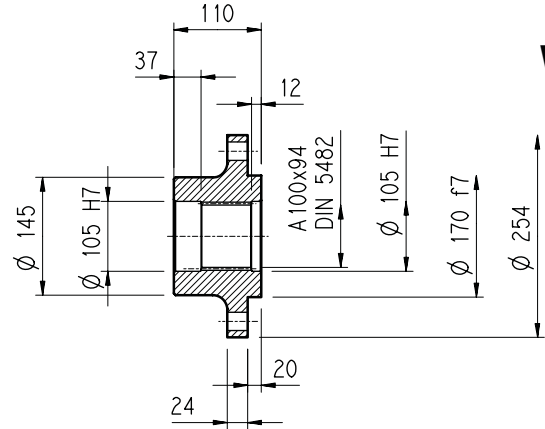
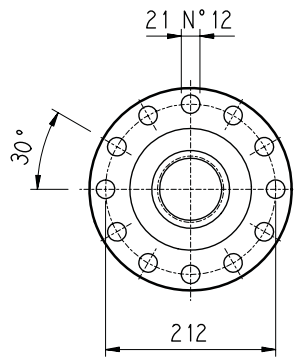
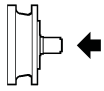

WOA

Materiale : Acciaio C40
Material : Steel C40
Material : Stahl C40
Màterial : Acier C40

Pignoni per rotazione / Output pinions
Ritzel / Pignons

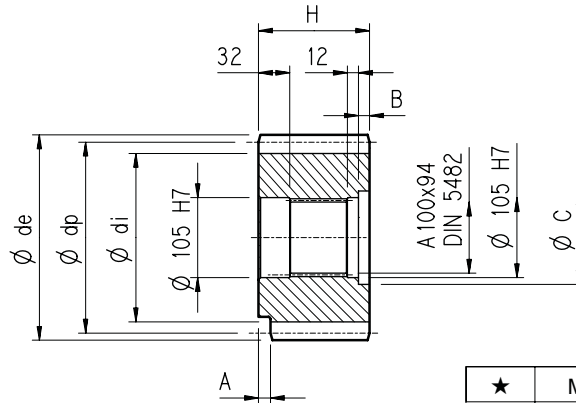
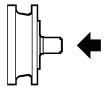

P...

	m	z	x	dp	di	de	H	A	B	C	★
PLQ	12	23	0	276	246	300	110	0	0	0	■
PPD	16	13	0.500	208	184	252.5	145	0	35	116	■
PPF	16	15	0.450	240	215	280	125	0	15	120	□

★	Materiale/Material/Material/Màterial
■	Acciaio 39NiCrMo3 Bonificato Steel 39NiCrMo3 hardened and tempered Vergüteter Stahl 39NiCrMo3 Acier bonifié 39NiCrMo3
□	Acciaio 18NiCrMo5 Cementato e temprato Steel 18NiCrMo5 Case hardened Einsatzstahl 18NiCrMo5 Einsatzgehärtet Acier cémenté et tempré 18NiCrMo5

Manicotti lisci / Sleeve couplings
Naben / Manchons lisses a cannelure interieure

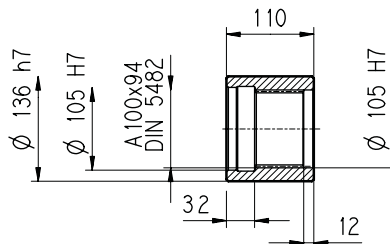
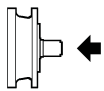

MOA

Materiale : Acciaio 16CrNi4
Material : Steel 16CrNi4
Material : Stahl 16CrNi4
Màterial : Acier 16CrNi4

Barre scanalate / Splined bars
Vielkeilwellen / Barre cannelée

B0A

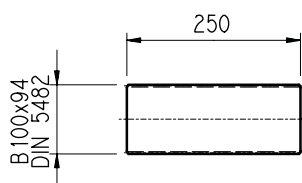
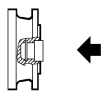

Mat. acciaio 18NiCrMo5 UNI 5331 da cementare e temprare 50-55 HRC
Case hardening steel 18NiCrMo5 UNI 5331
must be case hardened 50-55 HRC
Material: Einsatzstahl 18NiCrMo5 UNI 5331
muss einsatzgehärtet werden 50-55 HRC
Acier 18 NiCrMo5 UNI 5331 doit être cémenté trempé 50-55 HRC

Giunto ad attrito / Shrink disc
Schrumpfscheibe / Frette de serrage

G0A

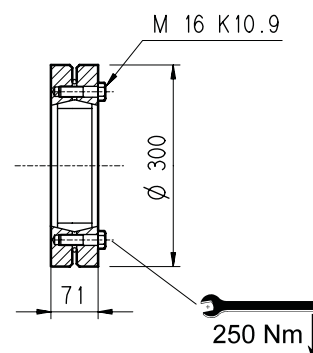
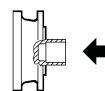

310L - 310R

Alberi veloci / Input shaft
Antriebswellen / Arbres d'entrée

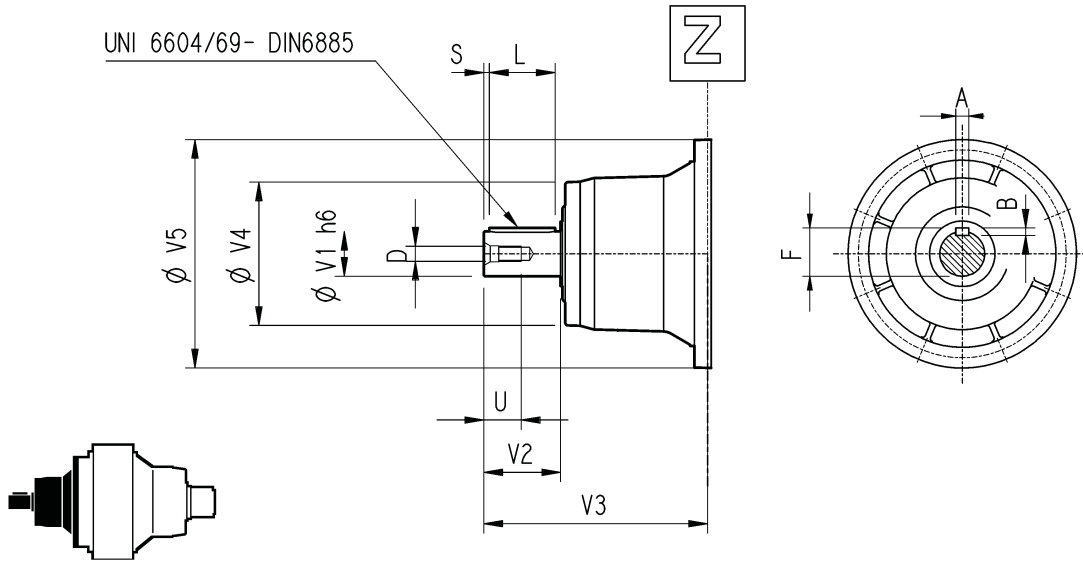

	CODE	V1	V2	V3	V4	V5	A	B	F	L	S	D	U
310 L1	V10B	80	130	377	200	400	22	14	85	110	10	M16	36
310 L2	V06B	60	105	307	155	292	18	11	64	90	7.5	M16	36
310 L3	V05B	48	82	239	155	245	14	9	51.5	70	6	M16	36
310 L4	V01A	24	36	137.5	120	186	8	7	27	30	3	M8	19
	V01B	38	58	158	120	186	10	8	41	50	4	M12	28
310 R2 (B)	V06B	60	105	307	155	292	18	11	64	90	7.5	M16	36
310 R2 (A)	V05B	48	82	239	155	245	14	9	51.5	70	6	M16	36
310 R3-R4	V01A	24	36	137.5	120	186	8	7	27	30	3	M8	19
	V01B	38	58	158	120	186	10	8	41	50	4	M12	28

Dimensioni d'entrata senza predisposizione motore
Input dimension without motor adaptor
Maße für den Antrieb ohne Motoradapter
Dimensions d'entrée sans prédisposition moteur

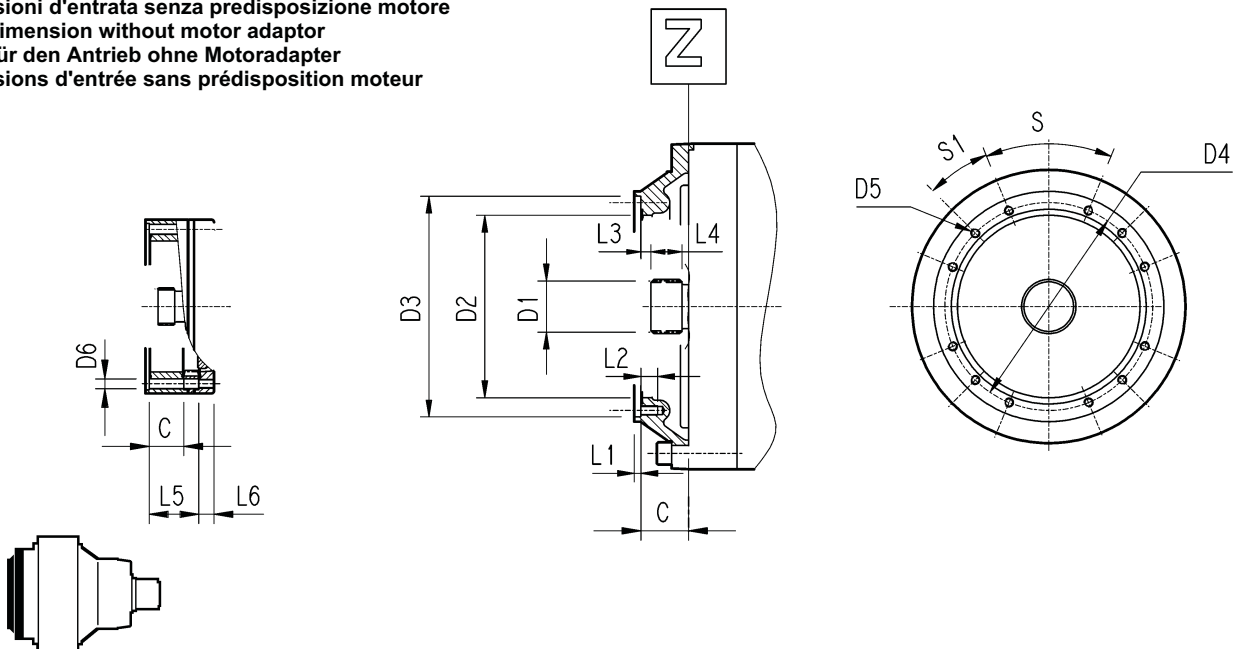

	C	D1	D2	D3	D4	D5	D6	L1	L2	L3	L4	L5	L6	S	S1	Entrata Input Antrieb Entrée
310 L1	88	70x64 DIN 5482	200	282 H7	266	M12 n°12	/	4	22	11	32	/	/	45°	45°	C
310 L2	45	58x53 DIN 5482	195	236 H7	222	M10 n°12	/	4	18	11	22	/	/	45°	22.5°	B
310 L3	37	40x36 DIN 5482	140	178 H7	165	M10 n°8	0	4	18	9	18	0	0	45°	45°	A
310 L4	37	40x36 DIN 5482	140	178 H7	165	M10 n°8	11	4	0	9	18	53	18	45°	45°	A
310 R2 (B)	45	58x53 DIN 5482	195	236 H7	222	M10 n°12	/	4	18	11	22	/	/	45°	22.5°	B
310 R2 (A)-R3-R4	37	40x36 DIN 5482	140	178 H7	165	M10 n°8	11	4	/	9	18	37	18	45°	45°	A

310L - 310R

Carichi radiali ed assiali ammissibili sull'albero lento per un valore di $F_{h2} : n_2 \cdot h = 10\ 000$

Permissible radial and axial loads on output shaft with $F_{h2} : n_2 \cdot h = 10\ 000$

An der Ausgangswelle zulässige Radiallasten und Axialkräfte für einen Wert von $F_{h2} : n_2 \cdot h = 10\ 000$

Charges radiales et axiales admises sur l'arbre lent pour une valeur de $F_{h2} : n_2 \cdot h = 10\ 000$

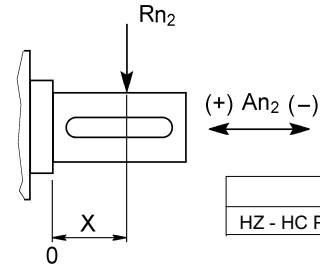
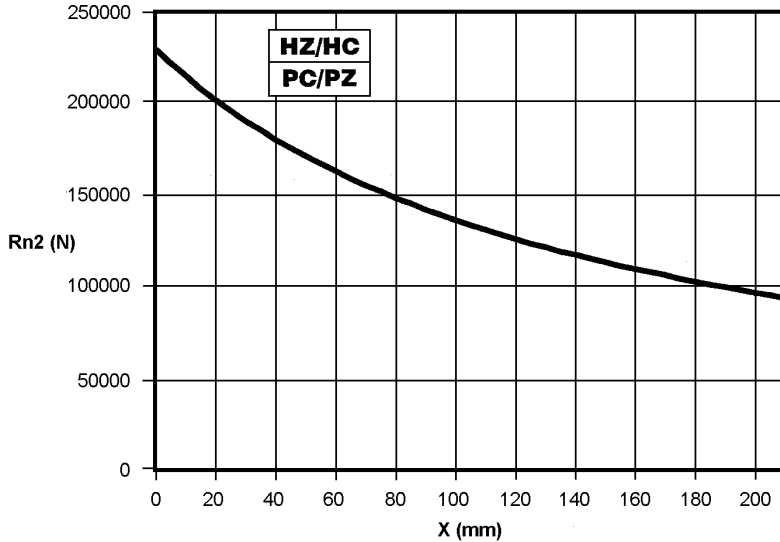

	An2 (+)	An2 (-)
HZ - HC PC - PZ	170 000	100 000

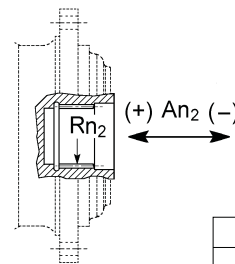

	Rn2	An2 (+/-)
FZ	65 000	52 000

Fattore f_{h2} correttivo per carichi sugli alberi Load corrective factor f_{h2} on shafts Korrektionsfaktor f_{h2} für wellenbelastungen Facteur de correction f_{h2} pour charges sur les arbres	f_{h2}	$F_{h2} = n_2 \cdot h$	10 000	25 000	50 000	100 000	500 000	1 000 000
		FZ	1	0.74	0.58	0.46	0.27	0.21
HZ - HC - PC - PZ	1	0.76	0.61	0.50	0.31	0.25		

Carichi radiali ammissibili sull'albero veloce per un valore di $F_{h1} : n_1 \cdot h = 250\ 000$

Permissible radial loads on input shaft with $F_{h1} : n_1 \cdot h = 250\ 000$

An der Antriebswelle zulässige Radiallasten für einen Wert von $F_{h1} : n_1 \cdot h = 250\ 000$

Charges radiales admises sur l'arbre d'entrée pour une valeur de $F_{h1} : n_1 \cdot h = 250\ 000$

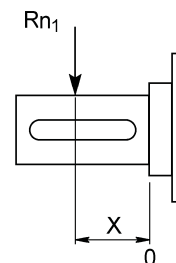
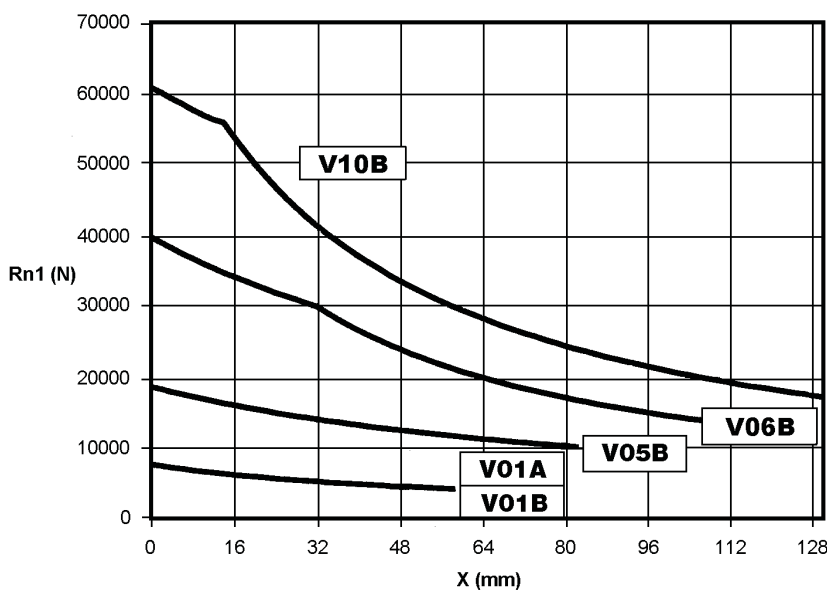

Fattore f_{h1} correttivo per carichi sugli alberi Load corrective factor f_{h1} on shafts Korrektionsfaktor f_{h1} für wellenbelastungen Facteur de correction f_{h1} pour charges sur les arbres	f_{h1}	$F_{h1} = n_1 \cdot h$	250 000	500 000	1 000 000	2 000 000	5 000 000	10 000 000
		1	0.79	0.63	0.50	0.37	0.29	