





307L

M₂ = 12500 Nm

	i	M _{n2} [Nm]						P ₁ [kW]	P _t [kW]	n ₁ [min ⁻¹]	n _{1max} [min ⁻¹]	M _b [Nm]	
		n ₂ ·h 10 000	n ₂ ·h 25 000	n ₂ ·h 50 000	n ₂ ·h 100 000	n ₂ ·h 500 000	n ₂ ·h 1 000 000						
L1	3.43	9 000	9 000	9 000	9 000	8 000	6 500	100	22	1 500	2 500	3 200	6L
	4.09	15 000	13 800	12 900	12 500	7 900	6 400	100	22	1 500	2 500	3 200	6L
	5.25	14 000	12 000	10 700	10 500	7 700	6 200	100	22	1 500	2 500	3 200	6L
	6.23	11 000	9 600	8 700	8 700	7 700	6 200	100	22	1 500	2 500	2 100	6G
L2	12.3	9 000	9 000	9 000	9 000	8 000	6 500	60	18	1 800	3 800	1 000	5K
	14.7	15 000	13 800	12 900	12 500	7 900	6 400	60	18	1 800	3 800	800	5G
	17.4	15 000	13 800	12 900	12 500	7 900	6 400	60	18	1 800	3 800	1 000	5K
	21.8	15 000	13 800	12 900	12 500	7 900	6 400	60	18	1 800	3 800	800	5G
	25.4	14 500	13 800	12 900	12 500	7 900	6 400	60	18	1 800	3 800	630	5E
	28.0	14 000	12 000	10 700	10 500	7 700	6 200	60	18	1 800	3 800	500	5C
	30.7	12 300	12 300	12 300	12 300	7 800	6 300	60	18	1 800	3 800	500	5C
	32.6	14 000	12 000	10 700	10 500	7 700	6 200	56	18	1 800	3 800	500	5C
	38.6	11 000	9 600	8 700	8 700	7 700	6 200	39	18	1 800	3 800	400	5B
	46.7	11 000	9 600	8 700	8 700	7 700	6 200	33	18	1 800	3 800	400	5B
L3	51.3	15 000	13 800	12 900	12 500	7 900	6 400	30	11	2 000	4 000	330	4H
	60.5	15 000	13 800	12 900	12 500	7 900	6 400	30	11	2 000	4 000	330	4H
	74.1	15 000	13 800	12 900	12 500	7 900	6 400	30	11	2 000	4 000	260	4F
	80.6	14 000	12 000	10 700	10 500	7 700	6 200	27	11	2 000	4 000	260	4F
	93.0	15 000	13 800	12 900	12 500	7 900	6 400	26	11	2 000	4 000	260	4F
	100	15 000	13 800	12 900	12 500	7 900	6 400	25	11	2 000	4 000	260	4F
	113	14 000	12 000	10 700	10 500	7 700	6 200	20	11	2 000	4 000	160	4D
	126	15 000	13 800	12 900	12 500	7 900	6 400	20	11	2 000	4 000	160	4D
	139	14 000	12 000	10 700	10 500	7 700	6 200	17.1	11	2 000	4 000	160	4D
	153	11 000	9 600	8 700	8 700	7 700	6 200	12.3	11	2 000	4 000	160	4D
	162	14 000	12 000	10 700	10 500	7 700	6 200	15.1	11	2 000	4 000	100	4B
	177	12 300	12 300	12 300	12 300	7 800	6 300	12.0	11	2 000	4 000	100	4B
	202	14 000	12 000	10 700	10 500	7 700	6 200	11.9	11	2 000	4 000	100	4B
	223	11 000	9 600	8 700	8 700	7 700	6 200	9.0	11	2 000	4 000	100	4B
	239	11 000	9 600	8 700	8 700	7 700	6 200	8.5	11	2 000	4 000	50	4A
	284	14 000	12 000	10 700	10 500	7 700	6 200	9.3	11	2 000	4 000	50	4A
336	11 000	9 600	8 700	8 700	7 700	6 200	6.4	11	2 000	4 000	50	4A	
L4	349	15 000	13 800	12 900	12 500	7 900	6 400	12.9	7.5	2 000	4 000	50	4A
	406	14 000	12 000	10 700	10 500	7 700	6 200	10.2	7.5	2 000	4 000	50	4A
	465	14 000	12 000	10 700	10 500	7 700	6 200	9.7	7.5	2 000	4 000	50	4A
	509	15 000	13 800	12 900	12 500	7 900	6 400	8.4	7.5	2 000	4 000	50	4A
	579	15 000	13 800	12 900	12 500	7 900	6 400	7.8	7.5	2 000	4 000	50	4A
	654	14 000	12 000	10 700	10 500	7 700	6 200	6.9	7.5	2 000	4 000	50	4A
	722	15 000	13 800	12 900	12 500	7 900	6 400	6.2	7.5	2 000	4 000	50	4A
	801	14 000	12 000	10 700	10 500	7 700	6 200	5.6	7.5	2 000	4 000	50	4A
	906	15 000	13 800	12 900	12 500	7 900	6 400	5.0	7.5	2 000	4 000	50	4A
	999	14 000	12 000	10 700	10 500	7 700	6 200	4.5	7.5	2 000	4 000	50	4A
	1 149	11 000	9 600	8 700	8 700	7 700	6 200	3.6	7.5	2 000	4 000	50	4A
	1 274	12 300	12 300	12 300	12 300	7 800	6 300	3.5	7.5	2 000	4 000	50	4A
	1 380	11 000	9 600	8 700	8 700	7 700	6 200	3.1	7.5	2 000	4 000	50	4A
	1 605	11 000	9 600	8 700	8 700	7 700	6 200	2.7	7.5	2 000	4 000	50	4A
	1 723	11 000	9 600	8 700	8 700	7 700	6 200	2.5	7.5	2 000	4 000	50	4A
	2 041	14 000	12 000	10 700	10 500	7 700	6 200	2.2	7.5	2 000	4 000	50	4A
2 423	11 000	9 600	8 700	8 700	7 700	6 200	1.9	7.5	2 000	4 000			

M_{2max} = 1.2 · M_{n2} (n₂ · h = 10 000)

M₂ = 12500 Nm
307R

	i	M _{n2} [Nm]						P ₁ [kW]	P _t [kW]	n ₁ [min ⁻¹]	n _{1max} [min ⁻¹]	M _b [Nm]	
		n ₂ ·h 10 000	n ₂ ·h 25 000	n ₂ ·h 50 000	n ₂ ·h 100 000	n ₂ ·h 500 000	n ₂ ·h 1 000 000						
R2	13.0	9 000	8 500	7 600	6 800	5 300	4 250	85	35	1 800	3 800	1 000	5K
	15.5	11 400	9 800	8 800	7 900	5 900	4 850	85	35	1 800	3 800	1 000	5K
	19.8	14 000	12 000	10 700	9 700	7 100	5 700	85	35	1 800	3 800	800	5G
	23.5	11 000	9 600	8 700	8 700	7 700	6 200	62	35	1 800	3 800	500	5C
R3	31.6	9 000	9 000	9 000	7 400	4 550	3 700	35	20	2 000	4 000	400	4K
	37.7	14 800	12 600	10 300	8 300	5 100	4 150	35	20	2 000	4 000	440	4L
	44.6	15 000	13 800	11 500	9 400	5 800	4 700	35	20	2 000	4 000	400	4K
	55.9	15 000	13 800	12 900	11 000	6 800	5 500	35	20	2 000	4 000	330	4H
	65.0	14 500	13 800	12 900	12 200	7 500	6 100	35	20	2 000	4 000	260	4F
	71.8	14 000	12 000	10 700	10 500	7 700	6 200	30	20	2 000	4 000	260	4F
	78.6	12 300	12 300	12 300	12 300	7 800	6 300	27	20	2 000	4 000	260	4F
	83.4	14 000	12 000	10 700	10 500	7 700	6 200	26	20	2 000	4 000	260	4F
	99.0	11 000	9 600	8 700	8 700	7 700	6 200	17.9	20	2 000	4 000	160	4D
	120	11 000	9 600	8 700	8 700	7 700	6 200	15.3	20	2 000	4 000	160	4D
R4	152	15 000	13 800	12 900	12 500	7 900	6 400	15.0	14	2 000	4 000	100	4B
	165	14 000	12 000	10 700	10 500	7 700	6 200	15.0	14	2 000	4 000	100	4B
	191	15 000	13 800	12 900	12 500	7 900	6 400	15.0	14	2 000	4 000	100	4B
	206	15 000	13 800	12 900	12 500	7 900	6 400	15.0	14	2 000	4 000	100	4B
	232	14 000	12 000	10 700	10 500	7 700	6 200	15.0	14	2 000	4 000	100	4B
	258	15 000	13 800	12 900	12 500	7 900	6 400	15.0	14	2 000	4 000	100	4B
	284	14 000	12 000	10 700	10 500	7 700	6 200	14.9	14	2 000	4 000	100	4B
	313	11 000	9 600	8 700	8 700	7 700	6 200	10.8	14	2 000	4 000	50	4A
	331	14 000	12 000	10 700	10 500	7 700	6 200	13.1	14	2 000	4 000	50	4A
	344	14 000	12 000	10 700	10 500	7 700	6 200	12.7	14	2 000	4 000	50	4A
	363	12 300	12 300	12 300	12 300	7 800	6 300	10.4	14	2 000	4 000	50	4A
	413	14 000	12 000	10 700	10 500	7 700	6 200	10.9	14	2 000	4 000	50	4A
	457	11 000	9 600	8 700	8 700	7 700	6 200	7.8	14	2 000	4 000	50	4A
	490	11 000	9 600	8 700	8 700	7 700	6 200	7.4	14	2 000	4 000	50	4A
	581	14 000	12 000	10 700	10 500	7 700	6 200	7.8	14	2 000	4 000	50	4A
	690	11 000	9 600	8 700	8 700	7 700	6 200	7.4	14	2 000	4 000	50	4A

$$M_{2max} = 1.2 \cdot M_{n2} \quad (n_2 \cdot h = 10\,000)$$

307L

		Motore idraulico / Hydraulic motor Hydraulikmotor/Moteur hydraulique							201			
		MG										
cm³	50	80	100	125	160	200	250	M2	M3	M4		
	M1	M1	M1	M1	M1	M1	M1	M2	M3	M4		
307L2	-	-	188	192	199	206	215	135	77	1/4G	20	

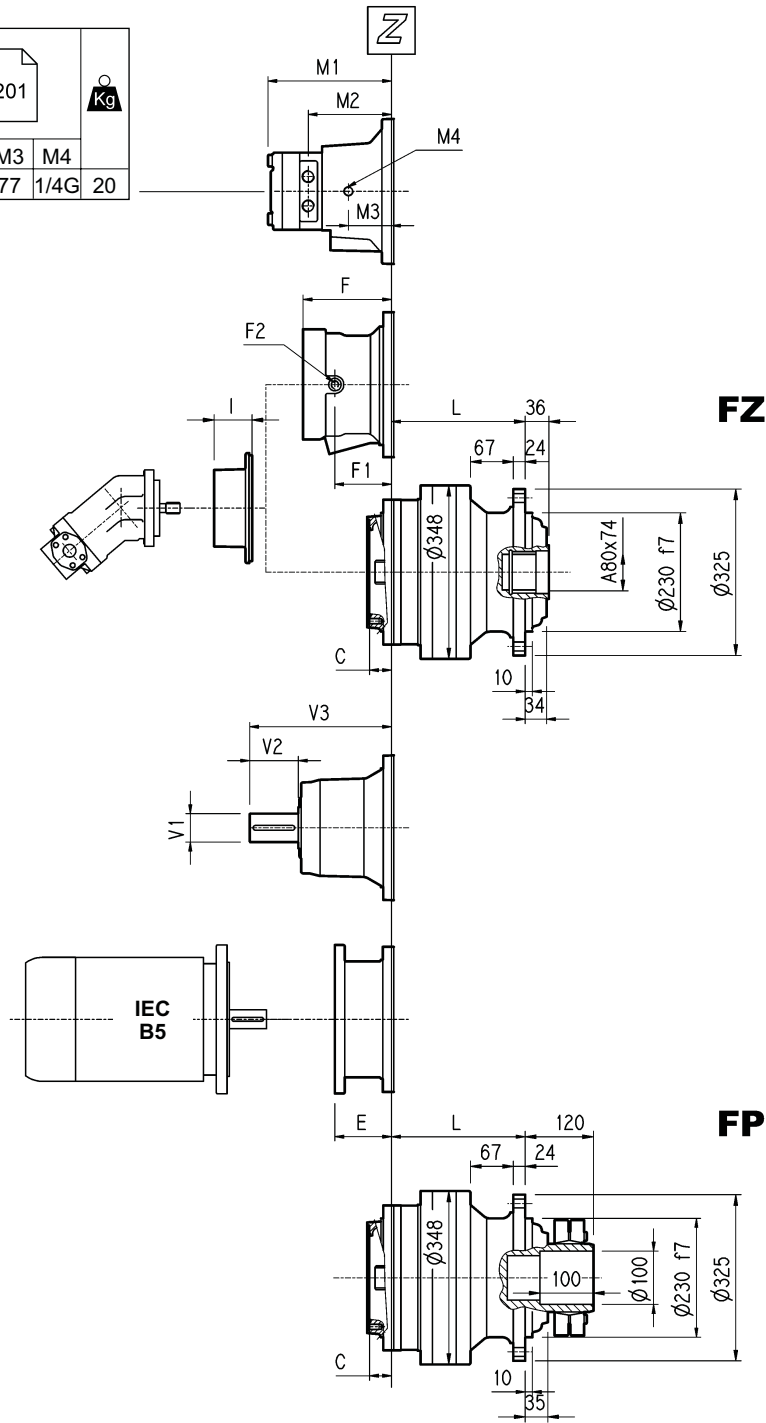

VERSIONE FP FP VERSION VERSION FP VERSION FP	COPPIA MAX. TRASMISSIBILE MAX. TRANSMISSIBLE TORQUE MAX. ÜBERTR. MOMENT COUPLE MAX. TRANSMISSIBLE	18 000 Nm
---	---	------------------

	L														Tipo Type Typ Type	Entrata Input Antrieb Entrée	
	MZ	MC	FZ	FP	HZ	HC	PC	PZ	C	Entrata Input Antrieb Entrée	I	F	F1	F2			
307 L1	165	165	210	246	95	85	105	120	51	B		201	153	1/4 G	6	B	28
307 L2	254	254	299	335	107	97	117	132	37	A		145	95	1/4 G	5	A	16
307 L3	319	319	364	400	114	104	124	139	37	A		105	65	1/4 G	4	A	10
307 L4	372	372	417	453	118	108	128	143	37	A		191	105	65	1/4 G	4	A

	V1	V2	V3		E														
						IEC 71	IEC 80	IEC 90	IEC 100	IEC 112	IEC 132	IEC 160	IEC 180	IEC 200	IEC 225	IEC 250			
307 L1	80	130	315	35	60	105	313	28											
307 L2	48	82	239	15										114	144	144			
307 L3	24	36	137.5	6	38	58	158	7	65	84	84	94	94	114	144				
307 L4	24	36	137.5	6	38	58	158	7	65	84	84	94	94	114	144				

307R

		Motore idraulico / Hydraulic motor Hydraulikmotor/Moteur hydraulique							201			Kg
		MG										
cm ³	50	80	100	125	160	200	250	M2	M3	M4		
	M1	M1	M1	M1	M1	M1	M1					
307R2	-	-	166	170	177	184	193	113	60	1/4G	14	
307R3	-	162	166	170	177	184	193	113	60	1/4G	14	

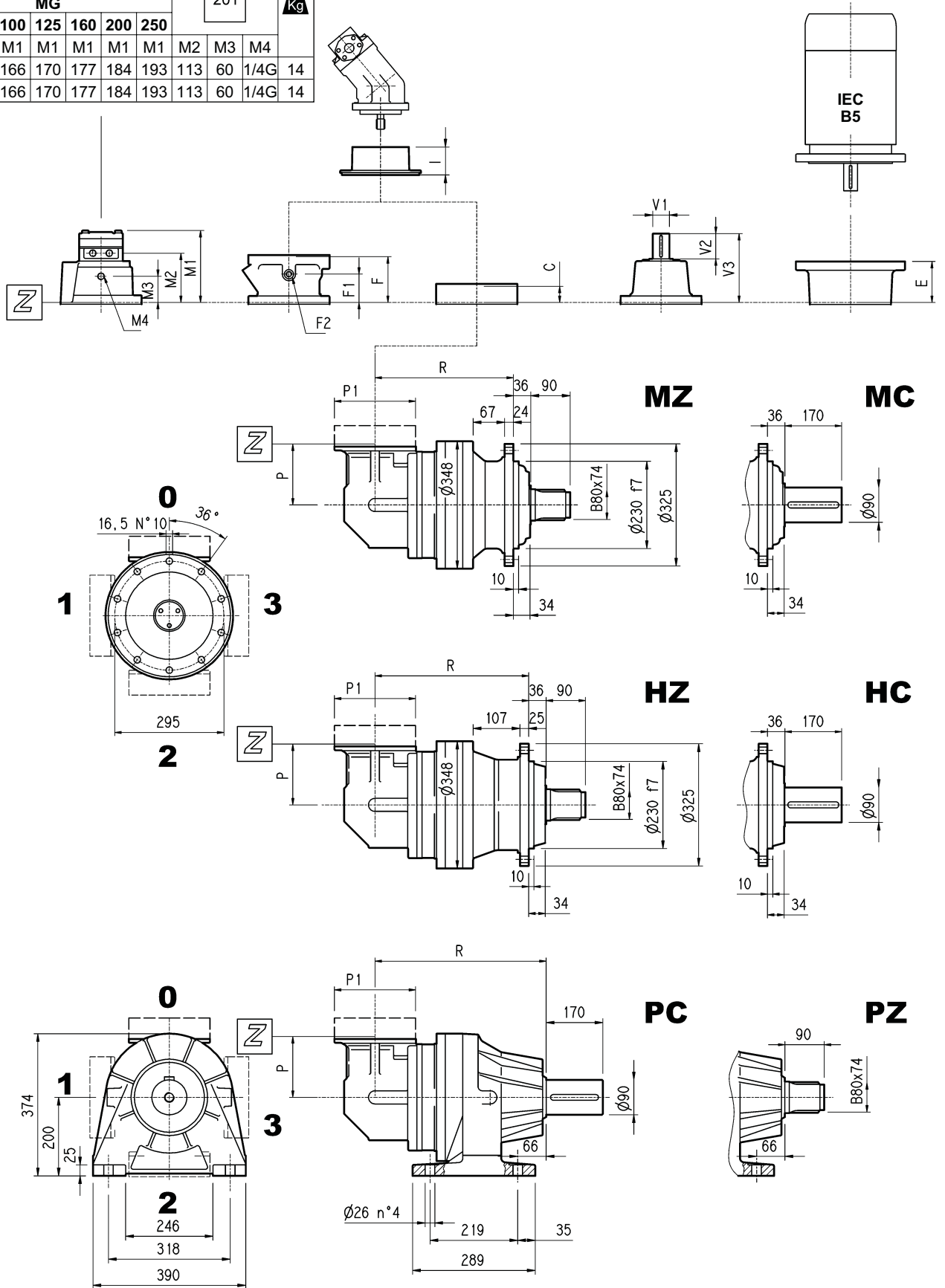

307R

		Motore idraulico / Hydraulic motor Hydraulikmotor/Moteur hydraulique							201			
		MG										
cm³	50	80	100	125	160	200	250	M2	M3	M4		
	M1	M1	M1	M1	M1	M1	M1					
307R2	-	-	166	170	177	184	193	113	60	1/4G	14	
307R3	-	162	166	170	177	184	193	113	60	1/4G	14	

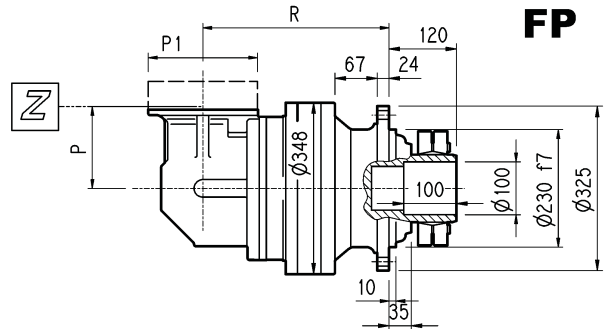
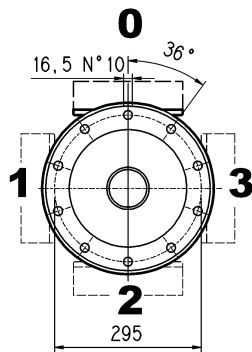
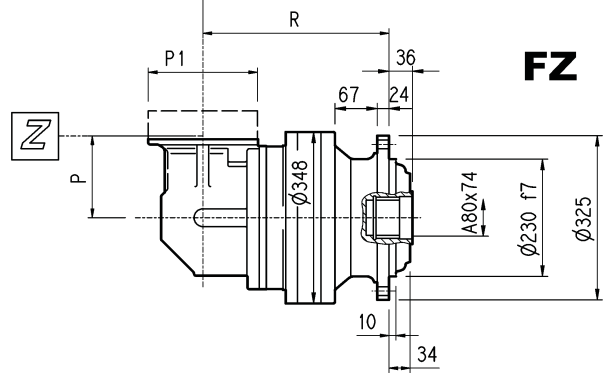
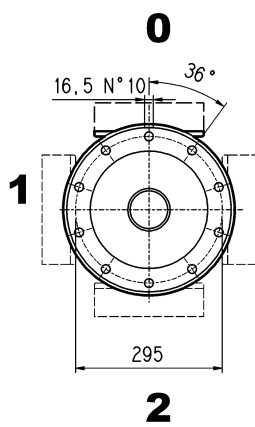
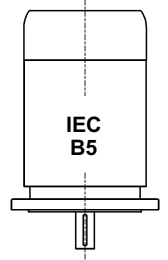
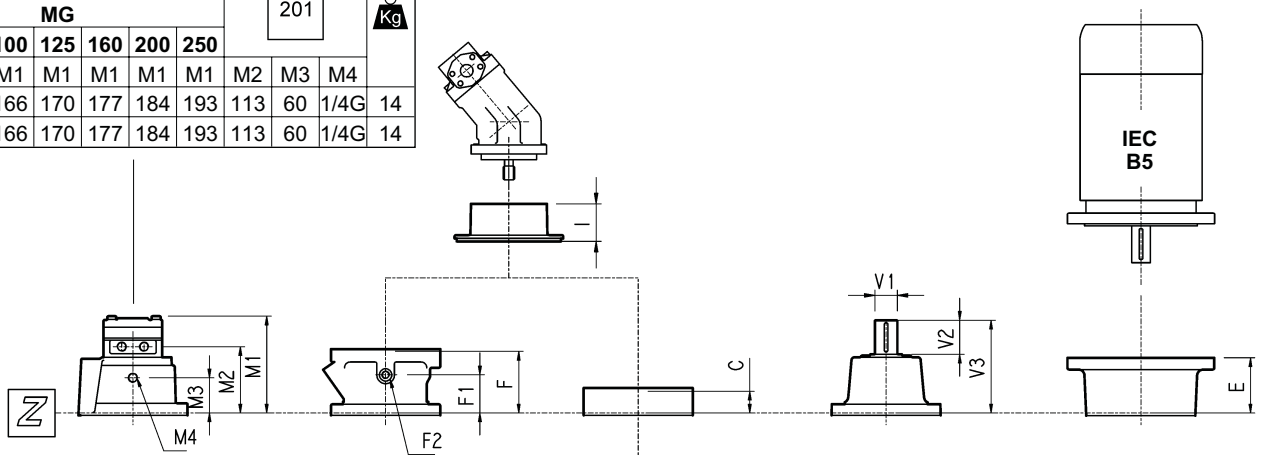

VERSIONE FP	COPPIA MAX. TRASMISSIBILE MAX. TRANSMISSIBLE TORQUE MAX. ÜBERTR. MOMENT COUPLE MAX. TRASMISSIBLE	18 000 Nm
FP VERSION		
VERSION FP		

	R				P	P1					C	Entrata Input Antrieb Entrée	I	F	F1	F2	Tipo Type Typ Type	Entrata Input Antrieb Entrée	
	MZ MC	FZ FP	HZ HC	PC PZ			MZ MC	FZ FP	HZ HC	PC PZ									
307 R2	284	284	329	365	225	245	145	135	155	170	37	A		145	95	1/4 G	5	A	16
307 R3	346	346	391	427	140	186	127	117	137	152	37	A		105	65	1/4 G	4	A	10
307 R4	411	411	456	492	122	186	128	118	138	153	37	A		105	65	1/4 G	4	A	10

	V1	V2	V3		V1	V2	V3		E								
									IEC 71	IEC 80	IEC 90	IEC 100	IEC 112	IEC 132	IEC 160	IEC 180	IEC 200
307 R2	48	82	239	15										114	144	144	174
307 R3	24	36	137.5	6	38	58	158	7	65	84	84	94	94	114	144		
307 R4	24	36	137.5	6	38	58	158	7	65	84	84	94	94	114	144		

307L - 307R

MC-HC

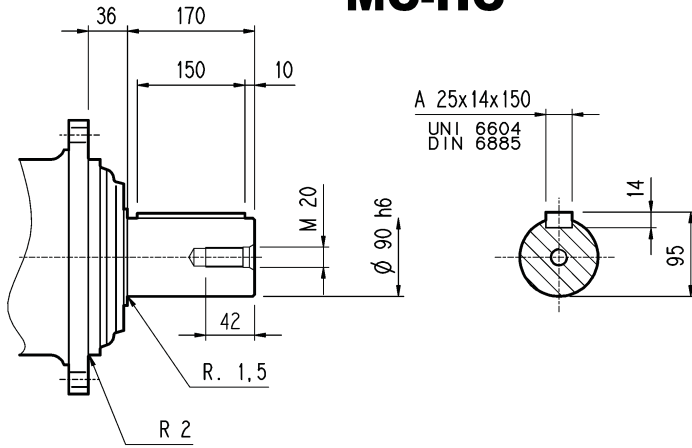

PC

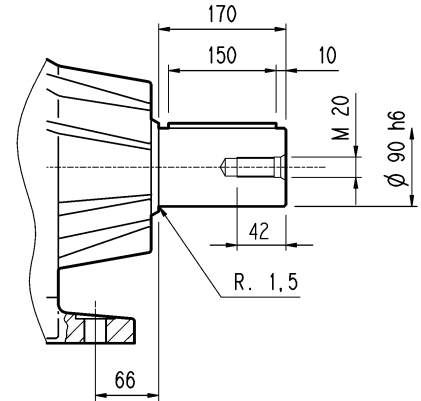

MZ-HZ

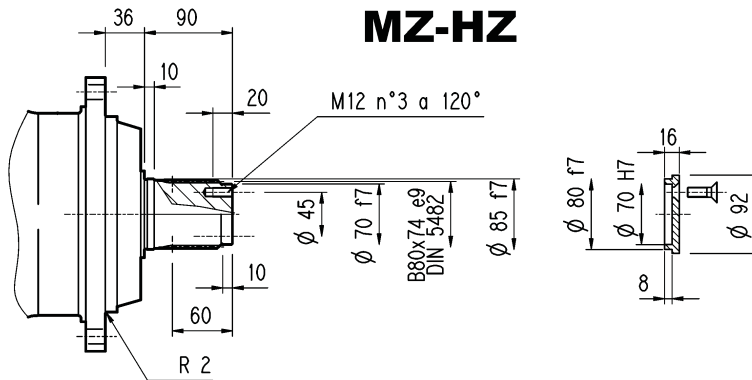

FZ

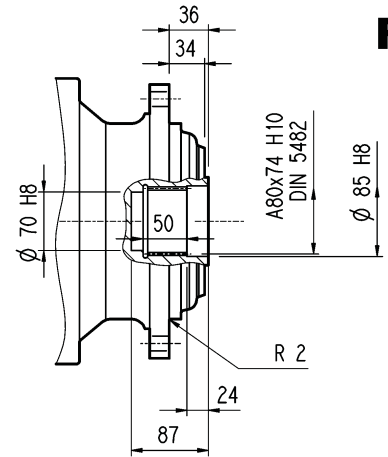

FP

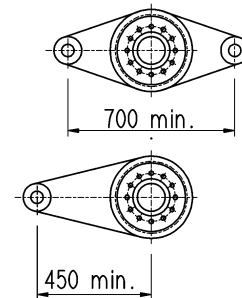
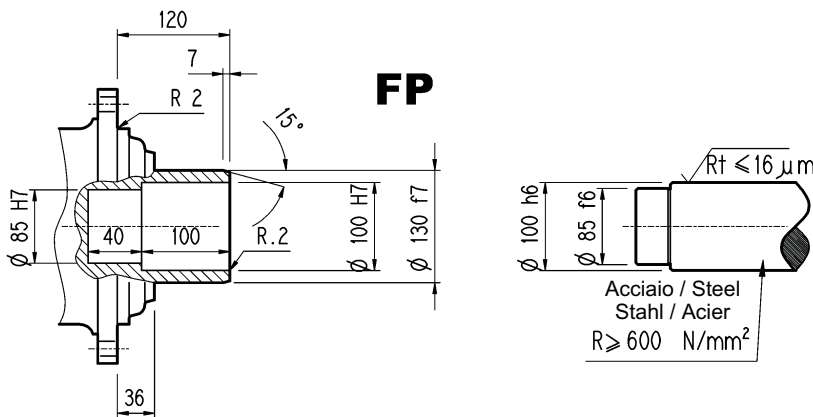

VERSIONE FP	COPPIA MAX. TRASMISSIBILE	18 000 Nm
FP VERSION	MAX. TRANSMISSIBLE TORQUE	
VERSION FP	MAX. ÜBERTR. MOMENT	
VERSION FP	COUPLE MAX. TRANSMISSIBLE	

Flangia / Flange
Flansch / Brides

307L - 307R

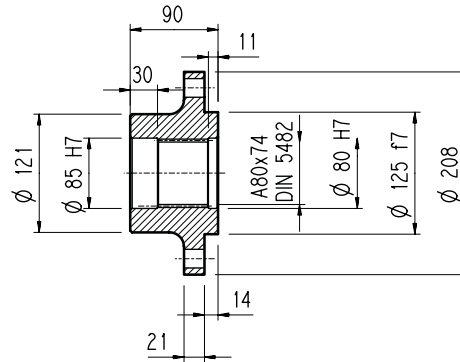
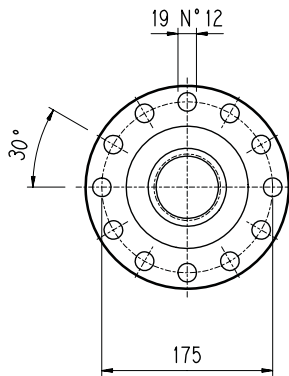
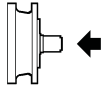

WOA

Materiale : Acciaio C40
Material : Steel C40
Material : Stahl C40
Materia : Acier C40

Pignoni per rotazione / Output pinions
Ritzel / Pignons

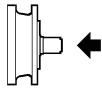

	m	z	x	dp	di	de	H	A	B	C	★
PFG	8	16	0.500	128	117	149.5	90	0	0	0	□
PHC	10	12	0.450	120	104	145	90	0	0	0	□
PHE	10	14	0.320	140	121	162.5	116	13	26	95	□
PHF	10	15	0.150	150	130	171.5	107	20	17	100	□
PHG	10	16	0.500	160	145	186	90	0	0	0	■
PHH1	10	17	0	170	145	190	90	0	0	0	■
PHH2	10	17	0.500	170	154	198	90	0	0	0	■
PLD	12	13	0.500	156	138	192	102	0	12	95	□
PLE	12	14	0.500	168	150	199.2	90	0	0	0	□
PLI	12	18	0.500	216	198	249.6	107	7	17	95	□
PLT	12	26	0	312	282	336	90	10	0	0	■

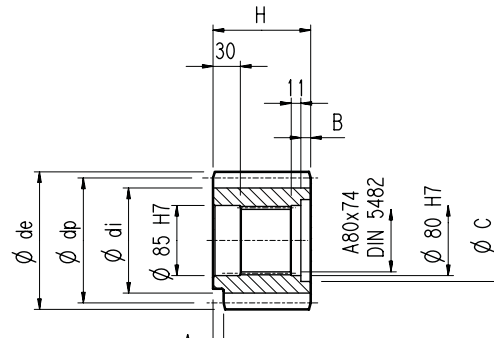

P...

★	Materiale/Material/Material/Materia
□	Acciaio 39NiCrMo3 Bonificato Steel 39NiCrMo3 hardened and tempered Vergüteter Stahl 39NiCrMo3 Acier bonifié 39NiCrMo3
■	Acciaio 18NiCrMo5 Cementato e temprato Steel 18NiCrMo5 Case hardened Einsatzstahl 18NiCrMo5 Einsatzgehärtet Acier cementé et tempré 18NiCrMo5

Manicotti lisci / Sleeve couplings
Naben / Manchons lisses a cannelure interieure

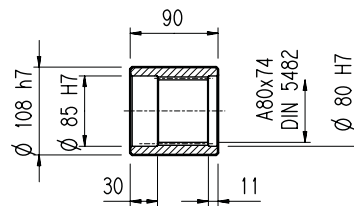
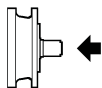

MOA

Materiale : Acciaio 16CrNi4
Material : Steel 16CrNi4
Material : Stahl 16CrNi4
Materia : Acier 16CrNi4

Barre scanalate / Splined bars
Vielkeilwellen / Barre cannelée

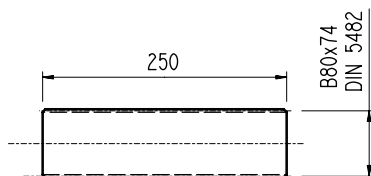
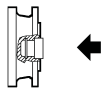

B0A

Mat. acciaio 18NiCrMo5 UNI 5331 da cementare e temprare 50-55 HRC
Case hardening steel 18NiCrMo5 UNI 5331
must be case hardened 50-55 HRC
Material: Einsatzstahl 18NiCrMo5 UNI 5331
muss einsatzgehärtet werden 50-55 HRC
Acier 18 NiCrMo5 UNI 5331 doit être cémenté trempé 50-55 HRC

Giunto ad attrito / Shrink disc
Schrumpfscheibe / Frette de serrage

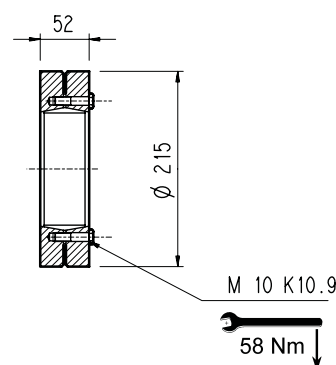
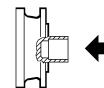

G0A

307L - 307R

Alberi veloci / Input shaft
Antriebswellen / Arbres d'entrée

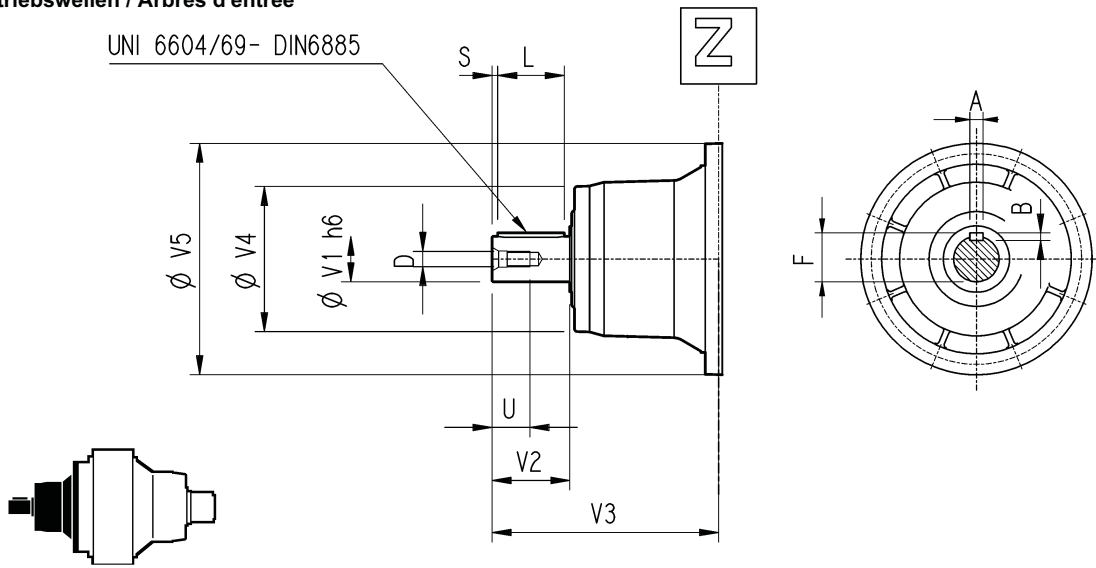

	CODE	V1	V2	V3	V4	V5	A	B	F	L	S	D	U
307 L1	V07B	80	130	315	200	345	22	14	85	110	10	M16	36
	V07A	60	105	313	155	345	18	11	64	90	7.5	M16	36
307 L2	V05B	48	82	239	155	245	14	9	51.5	70	6	M16	36
307 L3	V01A	24	36	137.5	120	186	8	7	27	30	3	M8	19
	V01B	38	58	158	120	186	10	8	41	50	4	M12	28
307 L4	V01A	24	36	137.5	120	186	8	7	27	30	3	M8	19
	V01B	38	58	158	120	186	10	8	41	50	4	M12	28
307 R2	V05B	48	82	239	155	245	14	9	51.5	70	6	M16	36
307 R3-R4	V01A	24	36	137.5	120	186	8	7	27	30	3	M8	19
	V01B	38	58	158	120	186	10	8	41	50	4	M12	28

Dimensioni d'entrata senza predisposizione motore
Input dimension without motor adaptor
Maße für den Antrieb ohne Motoradapter
Dimensions d'entrée sans prédisposition moteur

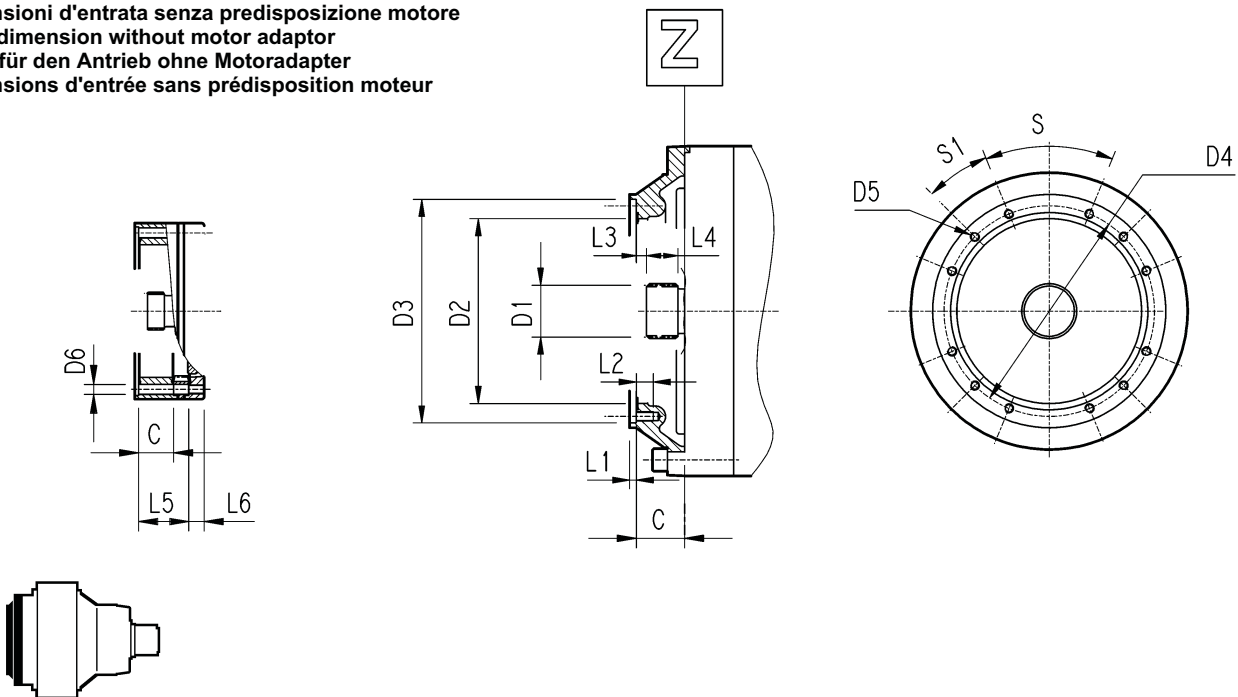

	C	D1	D2	D3	D4	D5	D6	L1	L2	L3	L4	L5	L6	S	S1	Entrata Input Antrieb Entrée
307 L1	51	58x53 DIN 5482	195	236 H7	222	M10 n°12	/	4	18	11	22	/	/	45°	22.5°	B
307 L2	37	40x36 DIN 5482	140	178 H7	165	M10 n°8	0	4	18	9	18	0	0	45°	45°	A
307 L3	37	40x36 DIN 5482	140	178 H7	165	M10 n°8	11	4	0	9	18	65	18	45°	45°	A
307 L4	37	40x36 DIN 5482	140	178 H7	165	M10 n°8	11	4	0	9	18	118	18	45°	45°	A
307 R2	37	40x36 DIN 5482	140	178 H7	165	M10 n°8	11	4	18	9	18	0	0	45°	45°	A
307 R3-R4	37	40x36 DIN 5482	140	178 H7	165	M10 n°8	11	4	/	9	18	37	18	45°	45°	A

307L - 307R

Carichi radiali ed assiali ammissibili sull'albero lento per un valore di $F_{h2} : n_2 \cdot h = 10\ 000$

Permissible radial and axial loads on output shaft with $F_{h2} : n_2 \cdot h = 10\ 000$

An der Ausgangswelle zulässige Radiallasten und Axialkräfte für einen Wert von $F_{h2} : n_2 \cdot h = 10\ 000$

Charges radiales et axiales admissibles sur l'arbre lent pour une valeur de $F_{h2} : n_2 \cdot h = 10\ 000$

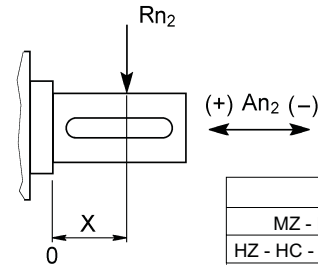
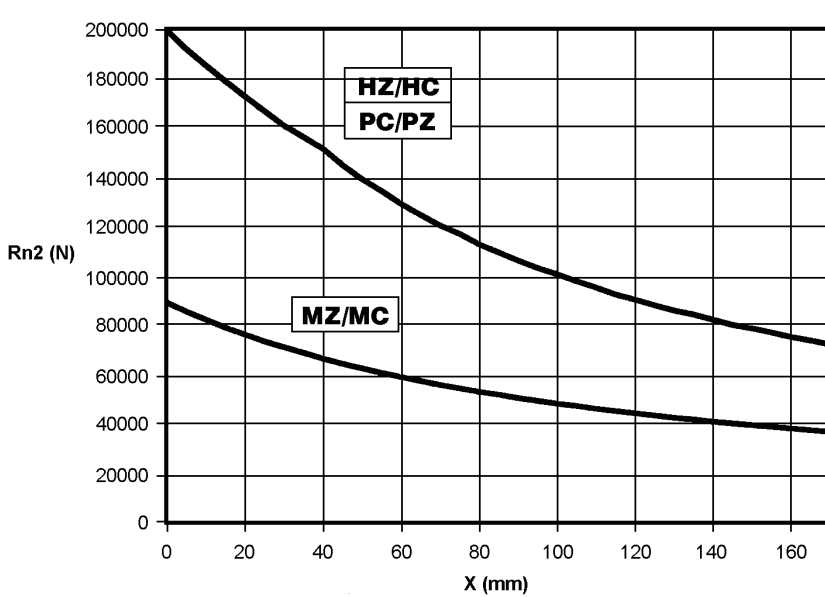

	An ₂ (+)	An ₂ (-)
MZ - MC	90 000	50 000
HZ - HC - PC - PZ	160 000	80 000

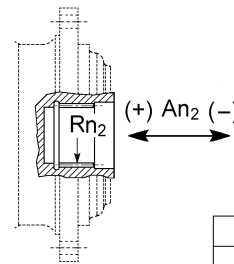

	Rn ₂	An ₂ (+/-)
FZ	45 000	45 000

Fattore f_{h2} correttivo per carichi sugli alberi Load corrective factor f_{h2} on shafts Korrektionsfaktor f_{h2} für wellenbelastungen Facteur de correction f_{h2} pour charges sur les arbres	$F_{h2} = n_2 \cdot h$						
		10 000	25 000	50 000	100 000	500 000	1 000 000
f_{h2}	MZ - MC - FZ	1	0.74	0.58	0.46	0.27	0.21
	HZ - HC - PC - PZ	1	0.76	0.61	0.50	0.31	0.25

Carichi radiali ammissibili sull'albero veloce per un valore di $F_{h1} : n_1 \cdot h = 250\ 000$

Permissible radial loads on input shaft with $F_{h1} : n_1 \cdot h = 250\ 000$

An der Antriebswelle zulässige Radiallasten für einen Wert von $F_{h1} : n_1 \cdot h = 250\ 000$

Charges radiales admises sur l'arbre d'entrée pour une valeur de $F_{h1} : n_1 \cdot h = 250\ 000$

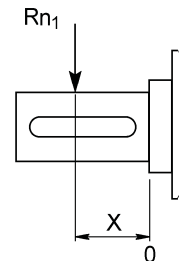
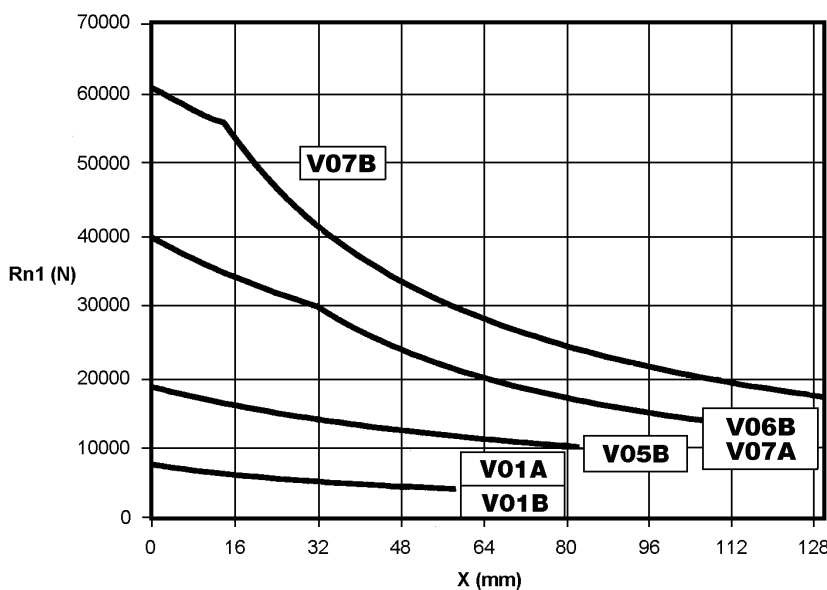

Fattore f_{h1} correttivo per carichi sugli alberi Load corrective factor f_{h1} on shafts Korrektionsfaktor f_{h1} für wellenbelastungen Facteur de correction f_{h1} pour charges sur les arbres	$F_{h1} = n_1 \cdot h$						
		250 000	500 000	1 000 000	2 000 000	5 000 000	10 000 000
f_{h1}	1	0.79	0.63	0.50	0.37	0.29	