



306L



M₂ = 8500 Nm

	i	M _{n2} [Nm]						P ₁ [kW]	P _t [kW]	n ₁ [min ⁻¹]	n _{1max} [min ⁻¹]	M _b [Nm]	
		n ₂ ·h 10 000	n ₂ ·h 25 000	n ₂ ·h 50 000	n ₂ ·h 100 000	n ₂ ·h 500 000	n ₂ ·h 1 000 000						
L1	3.60	8 300	7 900	7 700	7 500	6 700	5 400	75	18	1 500	3 000	2 600	6K
	4.25	10 000	9 600	9 400	9 300	6 000	4 850	75	18	1 500	3 000	2 600	6K
	5.33	9 500	8 500	7 800	7 800	5 700	4 600	75	18	1 500	3 000	2 100	6G
	6.20	8 500	7 200	6 500	6 500	5 700	4 650	75	18	1 500	3 000	1 500	6E
	7.50	7 000	5 900	5 500	5 500	4 700	3 850	75	18	1 500	3 000	1 100	6C
L2	13.0	7 600	7 300	7 300	7 300	5 100	4 150	40	13	1 800	3 800	800	5G
	15.3	8 300	7 900	7 700	7 500	5 100	4 150	40	13	1 800	3 800	800	5G
	18.1	10 000	9 600	9 400	9 300	5 800	4 700	40	13	1 800	3 800	630	5E
	22.7	9 300	9 100	9 100	9 100	5 700	4 600	40	13	1 800	3 800	500	5C
	26.4	7 500	7 400	7 400	7 400	4 650	3 750	40	13	1 800	3 800	400	5B
	28.4	9 500	8 500	7 800	7 800	5 700	4 600	40	13	1 800	3 800	400	5B
	33.1	9 300	8 500	7 800	7 800	5 400	4 400	40	13	1 800	3 800	400	5B
	38.4	8 500	7 200	6 500	6 500	5 750	4 650	29	13	1 800	3 800	400	5B
	46.5	8 500	7 200	6 500	6 500	5 750	4 650	25	13	1 800	3 800	400	5B
	56.3	7 000	5 900	5 500	5 500	4 700	3 850	17.3	13	1 800	3 800	400	5B
L3	45.1	7 600	7 300	7 300	7 200	4 450	3 600	20.0	7.5	2 000	4 000	260	4F
	53.2	8 300	7 900	7 700	7 500	5 000	4 050	20.0	7.5	2 000	4 000	260	4F
	65.2	8 300	7 900	7 700	7 500	4 800	3 900	20.0	7.5	2 000	4 000	160	4D
	77.0	10 000	9 600	9 400	8 700	5 400	4 400	20.0	7.5	2 000	4 000	160	4D
	81.9	8 100	7 700	7 700	7 500	5 000	4 100	16.2	7.5	2 000	4 000	160	4D
	88.3	8 900	8 700	8 700	7 400	4 550	3 700	17.0	7.5	2 000	4 000	160	4D
	104	10 000	9 600	9 400	8 300	5 100	4 150	16.3	7.5	2 000	4 000	160	4D
	112	7 500	7 400	7 400	7 400	4 600	3 750	11.4	7.5	2 000	4 000	160	4D
	121	9 500	8 500	7 800	7 800	5 700	4 600	13.1	7.5	2 000	4 000	100	4B
	141	9 300	8 500	7 800	7 800	5 400	4 400	11.4	7.5	2 000	4 000	100	4B
	152	7 500	7 400	7 400	7 400	4 650	3 750	8.5	7.5	2 000	4 000	100	4B
	184	6 800	6 800	6 800	6 800	4 850	3 950	6.4	7.5	2 000	4 000	100	4B
	205	9 500	8 500	7 800	7 800	5 700	4 600	8.3	7.5	2 000	4 000	100	4B
	222	8 500	7 200	6 500	6 500	5 700	4 650	7.1	7.5	2 000	4 000	50	4A
	238	9 300	8 500	7 800	7 800	5 400	4 400	7.0	7.5	2 000	4 000	50	4A
	268	7 000	5 900	5 500	5 500	4 700	3 850	5.0	7.5	2 000	4 000	50	4A
	288	7 000	5 900	5 500	5 500	4 700	3 850	4.7	7.5	2 000	4 000	50	4A
325	7 000	5 900	5 500	5 500	4 700	3 850	4.3	7.5	2 000	4 000	50	4A	
405	7 000	5 900	5 500	5 500	4 700	3 850	3.6	7.5	2 000	4 000	50	4A	
L4	444	10 000	9 600	9 400	8 300	5 100	4 150	6.8	6	2 000	4 000	50	4A
	509	8 900	8 700	8 700	7 400	4 550	3 700	5.3	6	2 000	4 000	50	4A
	589	9 500	8 500	7 800	7 800	5 700	4 600	4.7	6	2 000	4 000	50	4A
	636	8 900	8 700	8 700	7 400	4 550	3 700	4.3	6	2 000	4 000	50	4A
	700	9 500	8 500	7 800	7 800	5 700	4 600	4.3	6	2 000	4 000	50	4A
	809	7 500	7 400	7 400	7 400	4 650	3 750	3.3	6	2 000	4 000	50	4A
	877	7 500	7 400	7 400	7 400	4 650	3 750	3.1	6	2 000	4 000	50	4A
	1 015	9 300	8 500	7 800	7 800	5 400	4 400	3.0	6	2 000	4 000	50	4A
	1 095	7 500	7 400	7 400	7 400	4 650	3 750	2.6	6	2 000	4 000	50	4A
	1 279	8 500	7 200	6 500	6 500	5 700	4 650	2.4	6	2 000	4 000	50	4A
	1 475	9 500	8 500	7 800	7 800	5 700	4 600	2.0	6	2 000	4 000	50	4A
	1 597	8 500	7 200	6 500	6 500	5 700	4 650	1.9	6	2 000	4 000	50	4A
	1 872	7 000	5 900	5 500	5 500	4 700	3 850	1.6	6	2 000	4 000	50	4A
	2 074	7 000	5 900	5 500	5 500	4 700	3 850	1.5	6	2 000	4 000	50	4A
2 337	7 000	5 900	5 500	5 500	4 700	3 850	1.3	6	2 000	4 000	50	4A	
2 916	7 000	5 900	5 500	5 500	4 700	3 850	1.0	6	2 000	4 000	50	4A	

M_{2max} = 1.2 · M_{n2} (n₂ · h = 10 000)

M₂ = 8500 Nm

306R

	i	M _{n2} [Nm]						P ₁ [kW]	P _t [kW]	n ₁ [min ⁻¹]	n _{1max} [min ⁻¹]	M _b [Nm]	
		n ₂ ·h 10 000	n ₂ ·h 25 000	n ₂ ·h 50 000	n ₂ ·h 100 000	n ₂ ·h 500 000	n ₂ ·h 1 000 000						
R2	9.23	4 650	4 050	3 600	3 200	2 000	1 600	35	18	1 800	3 800	440	4L
	10.9	5 300	4 650	4 150	3 600	2 200	1 800	35	18	1 800	3 800	440	4L
	13.7	6 500	5 600	5 100	4 200	2 600	2 100	35	18	1 800	3 800	440	4L
	15.9	7 300	6 400	5 700	4 700	2 900	2 350	35	18	1 800	3 800	440	4L
	19.2	7 000	5 900	5 500	5 400	3 300	2 700	35	18	1 800	3 800	400	4K
R3	33.2	7 600	7 300	7 300	7 300	4 700	3 800	35	14	2 000	4 000	260	4F
	39.2	8 300	7 900	7 700	7 500	5 100	4 150	34	14	2 000	4 000	260	4F
	46.3	10 000	9 600	9 400	9 300	5 800	4 700	35	14	2 000	4 000	260	4F
	58.1	9 300	9 100	9 100	9 100	5 700	4 600	27	14	2 000	4 000	260	4F
	67.5	7 500	7 400	7 400	7 400	4 600	3 750	19	14	2 000	4 000	260	4F
	72.9	9 500	8 500	7 800	7 800	5 700	4 600	21	14	2 000	4 000	160	4D
	84.7	9 300	8 500	7 800	7 800	5 400	4 400	18	14	2 000	4 000	160	4D
	98.5	8 500	7 200	6 500	6 500	5 700	4 650	14	14	2 000	4 000	100	4B
	119	8 500	7 200	6 500	6 500	5 700	4 650	11.8	14	2 000	4 000	100	4B
	144	7 000	5 900	5 500	5 500	4 700	3 850	8.3	14	2 000	4 000	100	4B
R4	158	10 000	9 600	9 400	8 800	5 400	4 400	15.0	12	2 000	4 000	100	4B
	168	8 100	7 700	7 700	7 500	5 000	4 100	14.0	12	2 000	4 000	100	4B
	181	8 900	8 700	8 700	7 400	4 550	3 700	14.4	12	2 000	4 000	100	4B
	214	10 000	9 600	9 400	8 300	5 100	4 150	13.8	12	2 000	4 000	50	4A
	230	7 500	7 400	7 400	7 400	4 650	3 750	9.5	12	2 000	4 000	50	4A
	249	9 500	8 500	7 800	7 800	5 700	4 600	11.3	12	2 000	4 000	50	4A
	289	9 300	8 500	7 800	7 800	5 400	4 400	9.5	12	2 000	4 000	50	4A
	312	7 500	7 400	7 400	7 400	4 650	3 750	7.3	12	2 000	4 000	50	4A
	377	6 800	6 800	6 800	6 800	4 850	3 950	5.5	12	2 000	4 000	50	4A
	420	9 500	8 500	7 800	7 800	5 700	4 600	7.1	12	2 000	4 000	50	4A
	455	8 500	7 200	6 500	6 500	5 700	4 650	6.2	12	2 000	4 000	50	4A
	488	9 300	8 500	7 800	7 800	5 400	4 400	6.1	12	2 000	4 000	50	4A
	550	7 000	5 900	5 500	5 500	4 700	3 850	4.4	12	2 000	4 000	50	4A
	590	7 000	5 900	5 500	5 500	4 700	3 850	3.5	12	2 000	4 000	50	4A
	665	7 000	5 900	5 500	5 500	4 700	3 850	3.7	12	2 000	4 000	50	4A
	830	7 000	5 900	5 500	5 500	4 700	3 850	3.1	12	2 000	4 000	50	4A

M_{2max} = 1.2 · M_{n2} (n₂ · h = 10 000)

306L

		Motore idraulico / Hydraulic motor Hydraulikmotor/Moteur hydraulique							201			Kg
		MG										
cm ³	50	80	100	125	160	200	250	M2	M3	M4		
	M1	M1	M1	M1	M1	M1	M1	M2	M3	M4		
306L2	-	184	188	192	199	206	215	135	77	1/4G	20	

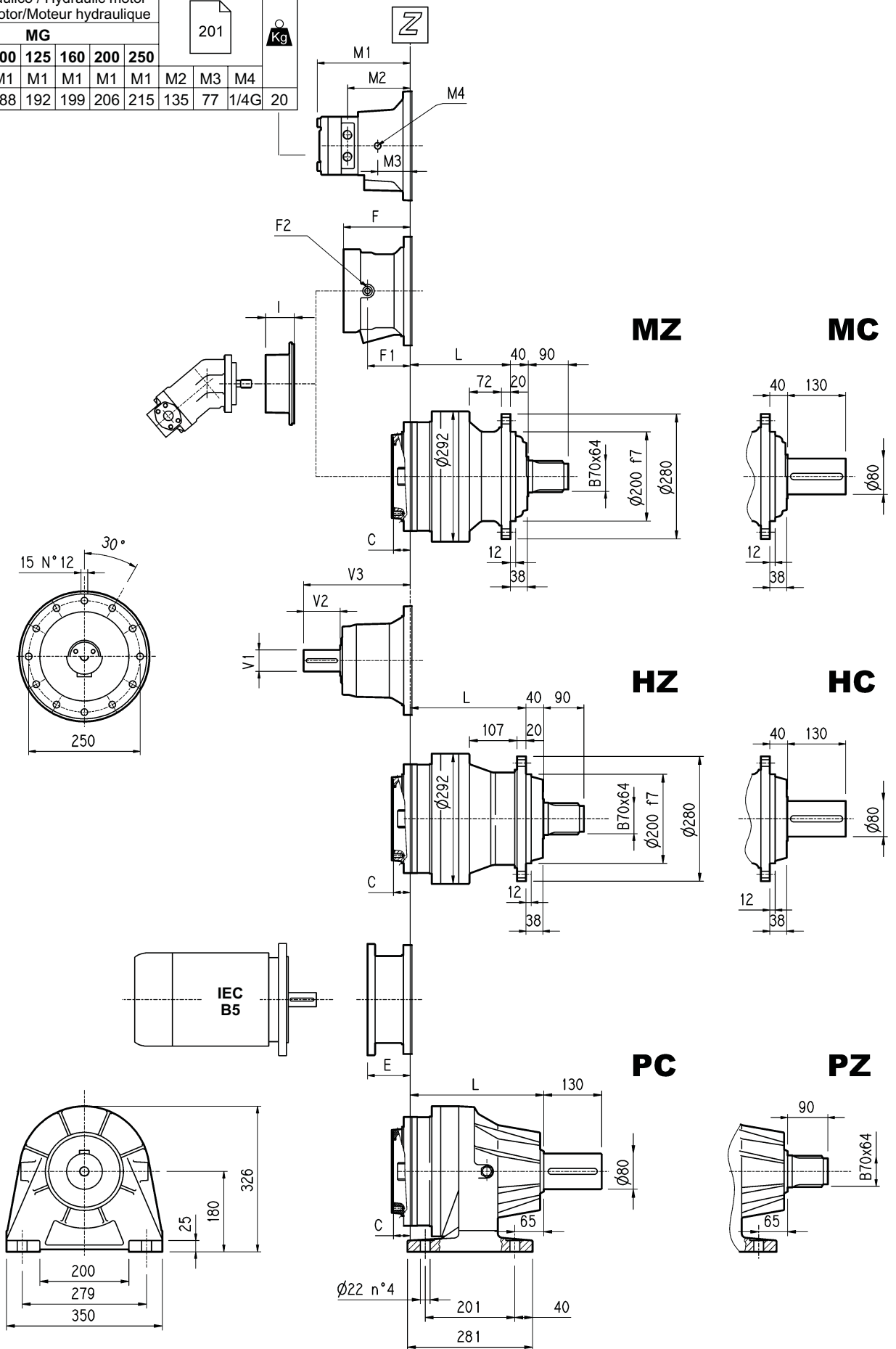

306L

		Motore idraulico / Hydraulic motor Hydraulikmotor/Moteur hydraulique							201			Kg
		MG										
cm ³	50	80	100	125	160	200	250	M2	M3	M4		
306L2	-	184	188	192	199	206	215	135	77	1/4G	20	

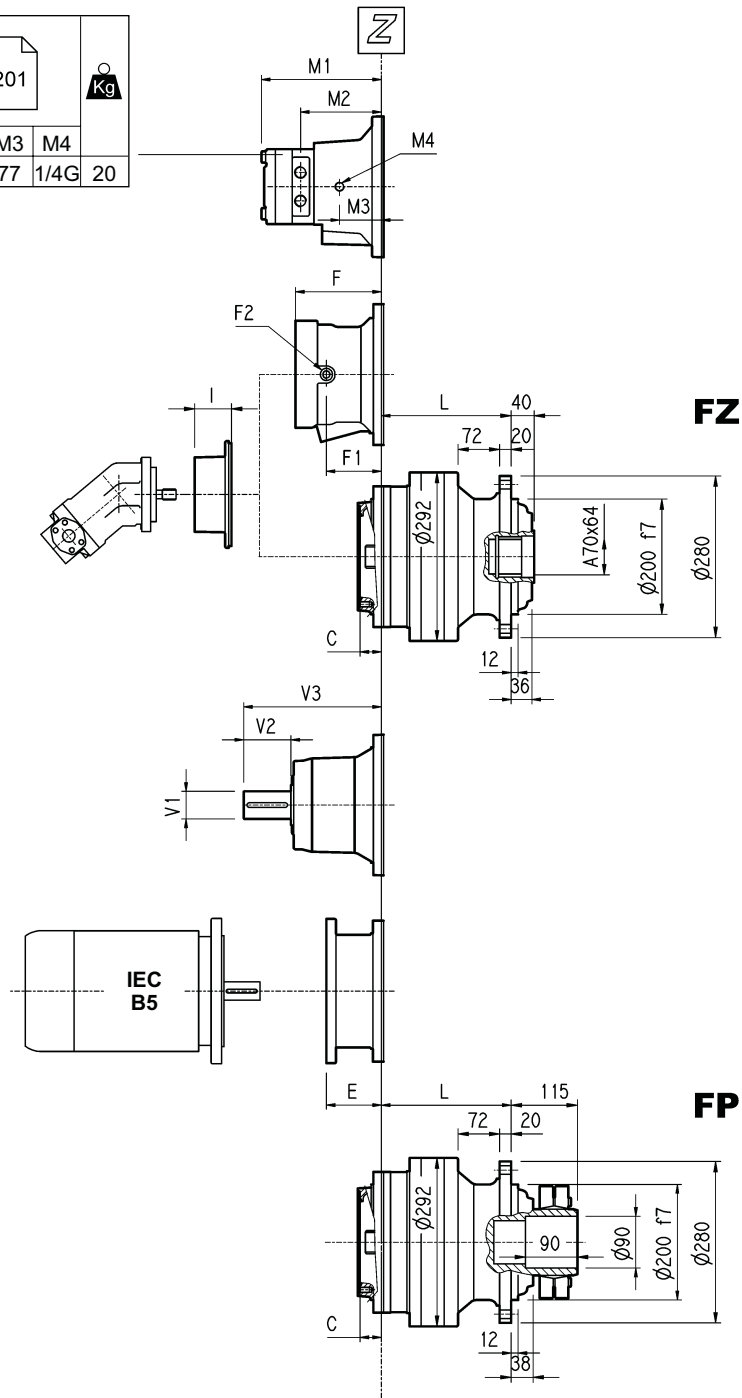

VERSIONE FP	COPPIA MAX. TRASMISSIBILE	12 000 Nm
FP VERSION	MAX. TRANSMISSIBLE TORQUE	
VERSION FP	MAX. ÜBERTR. MOMENT	
VERSION FP	COUPLE MAX. TRANSMISSIBLE	

	L				Kg				C	Entrata Input Antrieb Entrée	I	F	F1	F2	Tipo Type Typ Type	Entrata Input Antrieb Entrée	Kg
	MZ	MC	FZ	FP	HZ	HC	PC	PZ									
306 L1	160	160	195	235	65	65	70	80	45	B	195	147	1/4 G	6	B	28	
306 L2	225	225	260	300	74	74	79	89	37	A	145	95	1/4 G	5	A	16	
306 L3	278	278	313	353	78	78	83	93	37	A	105	65	1/4 G	4	A	10	
306 L4	331	331	366	406	82	82	87	97	37	A	191	105	65	1/4 G	4	A	10

	V1	V2	V3	Kg	V1	V2	V3	Kg	E										
									IEC 71	IEC 80	IEC 90	IEC 100	IEC 112	IEC 132	IEC 160	IEC 180	IEC 200	IEC 225	IEC 250
306 L1	60	105	307	23											152	152	182	212	193
306 L2	48	82	239	15										114	144	144	174		
306 L3	24	36	137.5	6	38	58	158	7	65	84	84	94	94	114	144				
306 L4	24	36	137.5	6	38	58	158	7	65	84	84	94	94	114	144				

306R

		Motore idraulico / Hydraulic motor Hydraulikmotor/Moteur hydraulique							201			Kg
cm ³		MG										
50	80	100	125	160	200	250	M2	M3	M4			
306R2	-	162	166	170	177	184	193	113	60	1/4G	14	
306R3	156	162	166	170	177	-	-	113	60	1/4G	14	

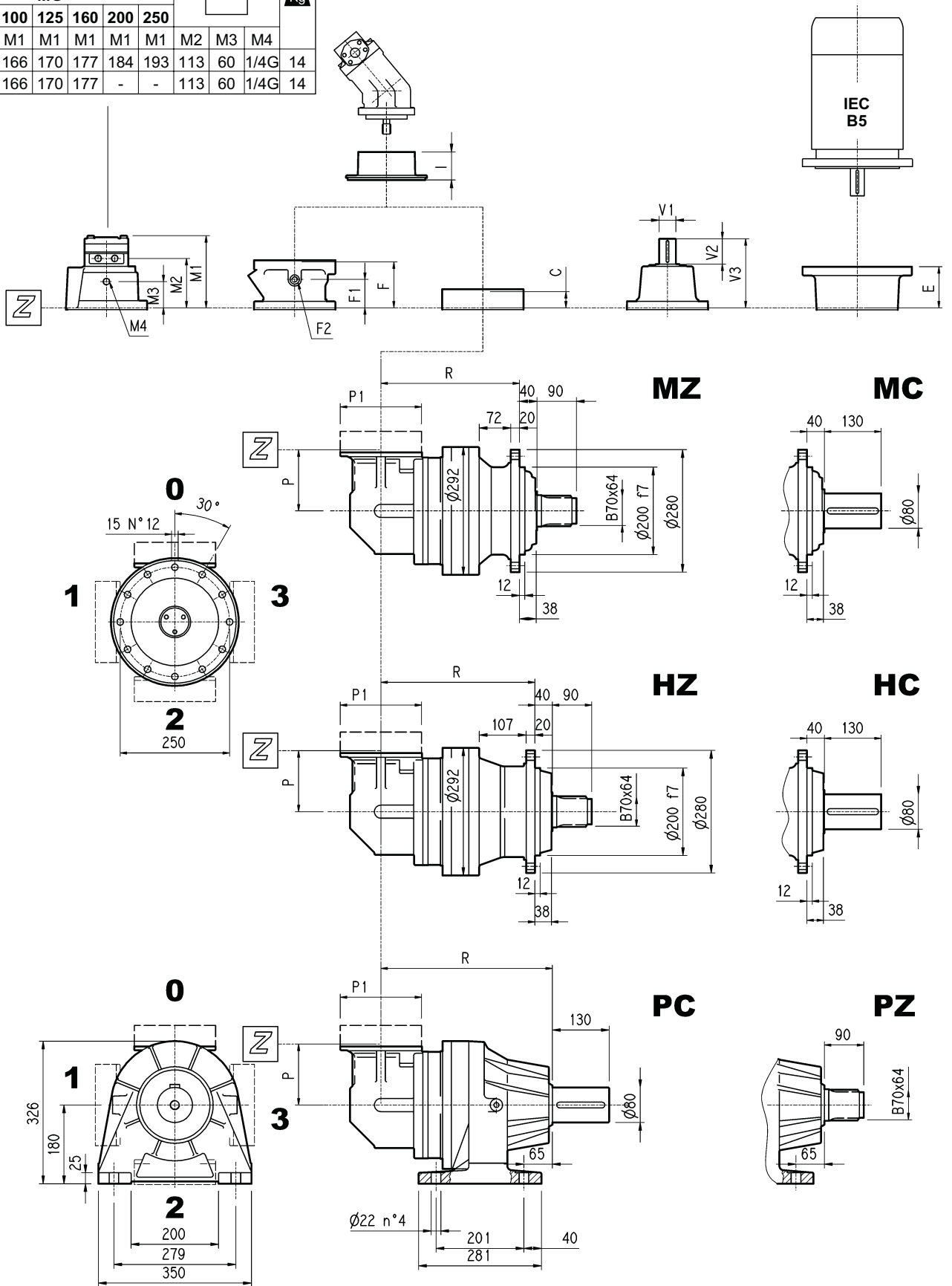

306R

		Motore idraulico / Hydraulic motor Hydraulikmotor/Moteur hydraulique							201			
		MG										
cm³	50	80	100	125	160	200	250	M2	M3	M4		
	M1	M1	M1	M1	M1	M1	M1					
306R2	-	162	166	170	177	184	193	113	60	1/4G	14	
306R3	156	162	166	170	177	-	-	113	60	1/4G	14	

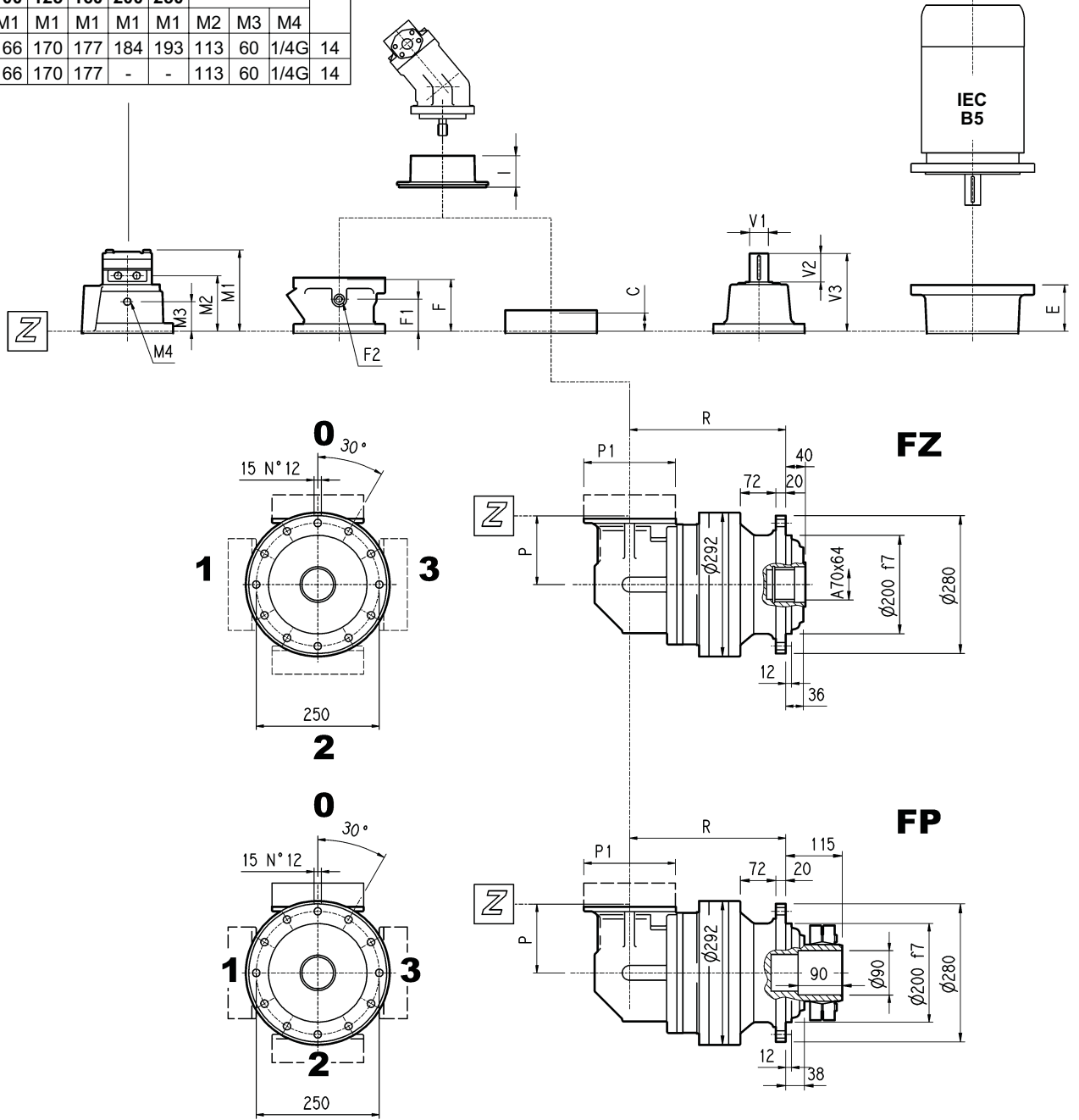

VERSIONE FP	COPPIA MAX. TRASMISSIBILE	12 000 Nm
FP VERSION	MAX. TRANSMISSIBLE TORQUE	
VERSION FP	MAX. ÜBERTR. MOMENT	
VERSION FP	COUPLE MAX. TRANSMISSIBLE	

	R				P	P1					C	Entrata Input Antrieb Entrée	I	F	F1	F2	Tipo Type Typ Type	Entrata Input Antrieb Entrée	
	MZ MC	FZ FP	HZ HC	PC PZ			MZ MC	FZ FP	HZ HC	PC PZ									
306 R2	297	297	332	372	140	186	89	89	94	104	37	A		105	65	1/4 G	4	A	10
306 R3	317	317	352	392	140	186	85	85	90	100	37	A		105	65	1/4 G	4	A	10
306 R4	370	370	405	445	122	186	79	79	84	94	37	A		105	65	1/4 G	4	A	10

	V1	V2	V3		V1	V2	V3		E						
									IEC 71	IEC 80	IEC 90	IEC 100	IEC 112	IEC 132	IEC 160
306 R2	24	36	137.5	6	38	58	158	7	65	84	84	94	94	114	144
306 R3	24	36	137.5	6	38	58	158	7	65	84	84	94	94	114	144
306 R4	24	36	137.5	6	38	58	158	7	65	84	84	94	94	114	144

306L - 306R

MC-HC

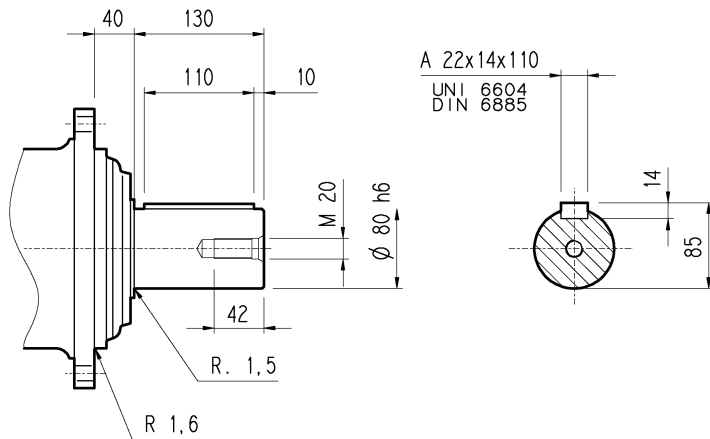

PC

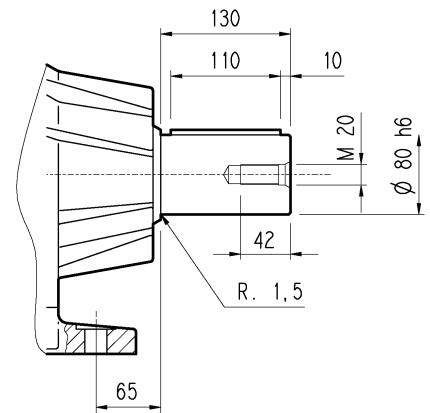

MZ-HZ

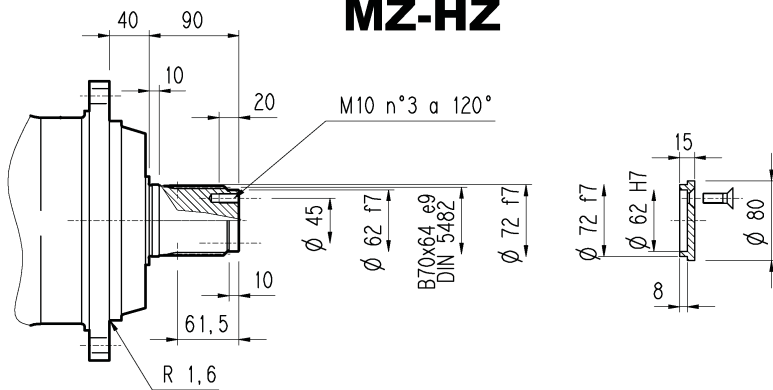

FZ

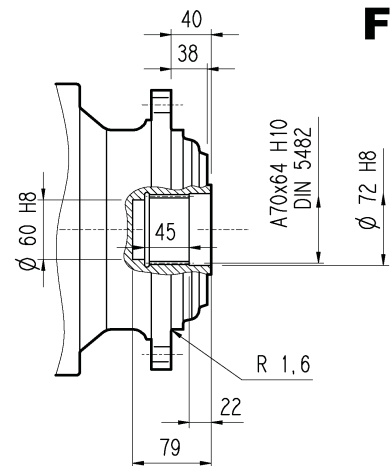

FP

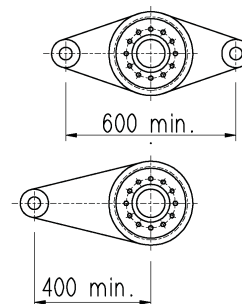
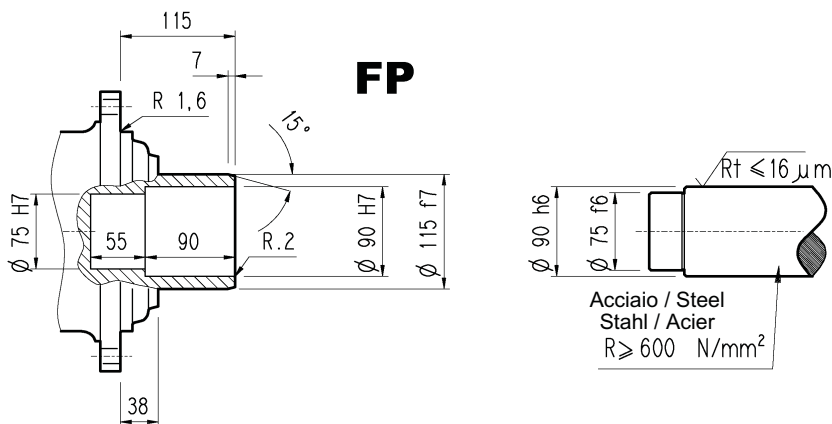

VERSIONE FP	COPPIA MAX. TRASMISSIBILE	12 000 Nm
FP VERSION	MAX. TRANSMISSIBLE TORQUE	
VERSION FP	MAX. ÜBERTR. MOMENT	
VERSION FP	COUPLE MAX. TRANSMISSIBLE	

306L - 306R

Alberi veloci / Input shaft
Antriebswellen / Arbres d'entrée

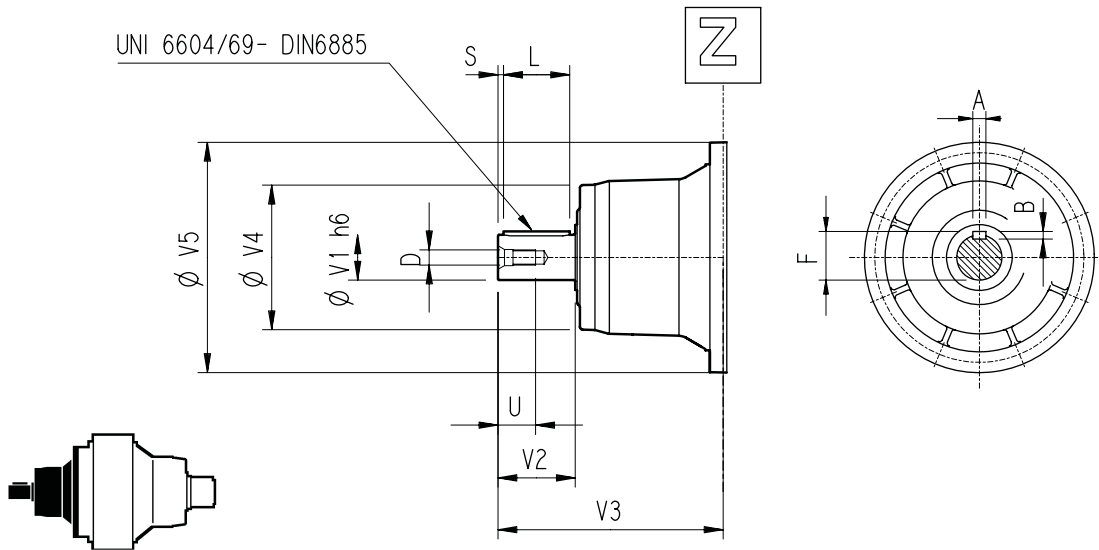

	CODE	V1	V2	V3	V4	V5	A	B	F	L	S	D	U
306 L1	V06B	60	105	307	155	292	18	11	64	90	7.5	M16	36
306 L2	V05B	48	82	239	155	245	14	9	51.5	70	6	M16	36
306 L3	V01A	24	36	137.5	120	186	8	7	27	30	3	M8	19
	V01B	38	58	158	120	186	10	8	41	50	4	M12	28
306 L4	V01A	24	36	137.5	120	186	8	7	27	30	3	M8	19
	V01B	38	58	158	120	186	10	8	41	50	4	M12	28
306 R2-R3-R4	V01A	24	36	137.5	120	186	8	7	27	30	3	M8	19
	V01B	38	58	158	120	186	10	8	41	50	4	M12	28

Dimensioni d'entrata senza predisposizione motore
Input dimension without motor adaptor
Maße für den Antrieb ohne Motoradapter
Dimensions d'entrée sans prédisposition moteur

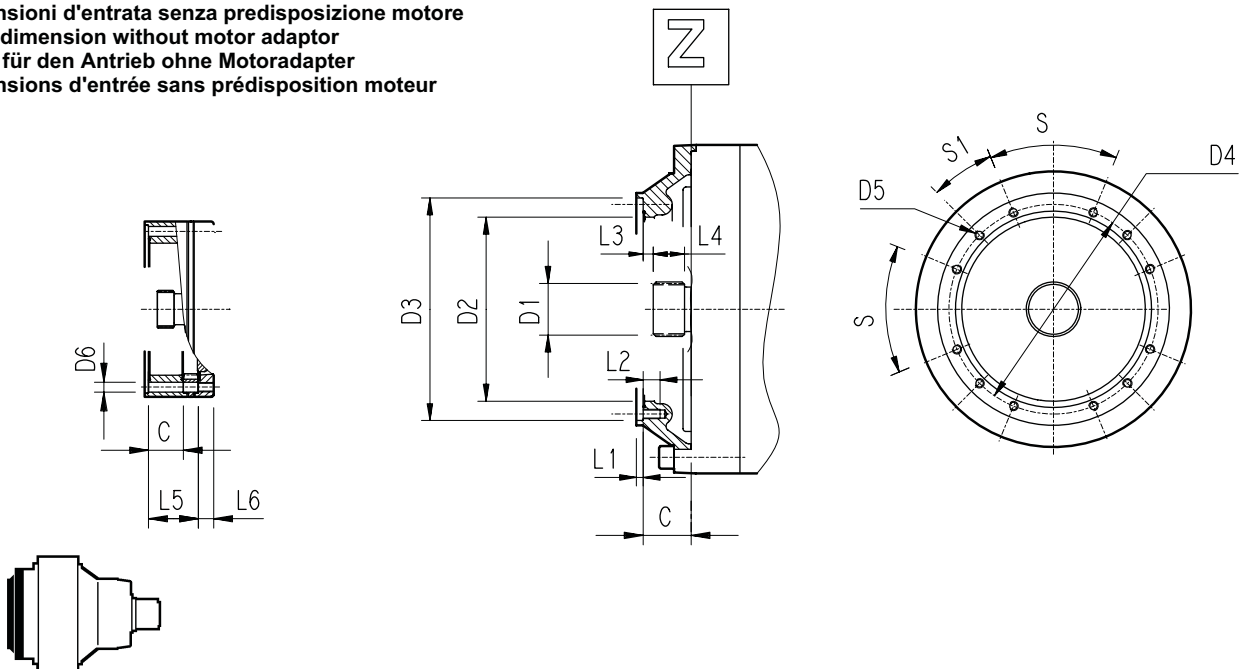

	C	D1	D2	D3	D4	D5	D6	L1	L2	L3	L4	L5	L6	S	S1	Entrata Input Antrieb Entrée
306 L1	45	58x53 DIN5482	195	236 H7	222	M10 n°12	/	4	18	11	22	/	/	45°	22.5°	B
306 L2	37	40x36 DIN5482	140	178 H7	165	M10 n°8	0	4	18	9	18	0	0	45°	45°	A
306 L3	37	40x36 DIN5482	140	178 H7	165	M10 n°8	11	4	/	9	18	53	18	45°	45°	A
306 L4	37	40x36 DIN5482	140	178 H7	165	M10 n°8	11	4	/	9	18	106	18	45°	45°	A
306 R2-R3-R4	37	40x36 DIN5482	140	178 H7	165	M10 n°8	11	4	/	9	18	37	18	45°	45°	A

306L - 306R

Carichi radiali ed assiali ammissibili sull'albero lento per un valore di $F_{h2} : n_2 \cdot h = 10\ 000$

Permissible radial and axial loads on output shaft with $F_{h2} : n_2 \cdot h = 10\ 000$

An der Ausgangswelle zulässige Radiallasten und Axialkräfte für einen Wert von $F_{h2} : n_2 \cdot h = 10\ 000$

Charges radiales et axiales admissibles sur l'arbre lent pour une valeur de $F_{h2} : n_2 \cdot h = 10\ 000$

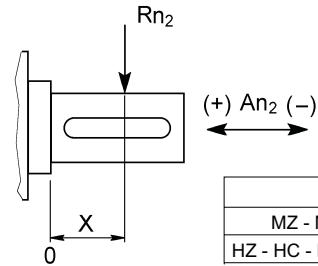
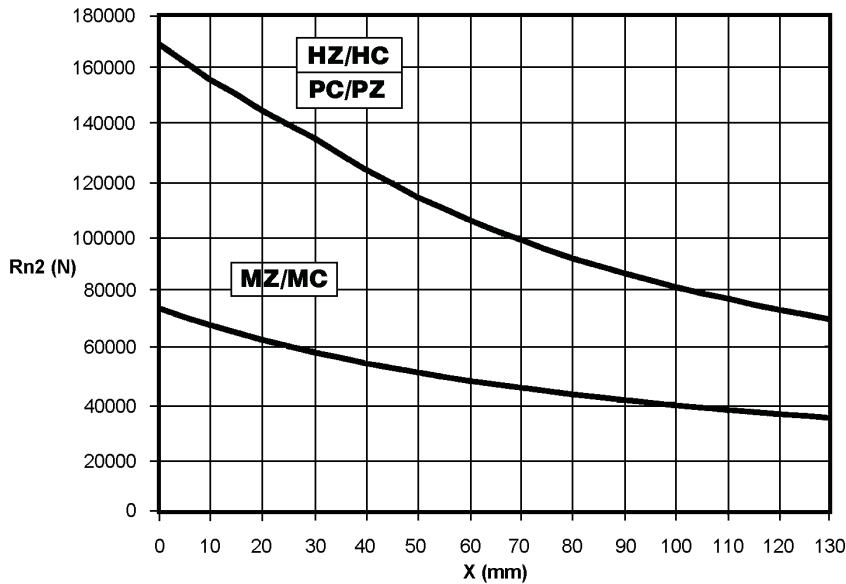

	An ₂ (+)	An ₂ (-)
MZ - MC	70 000	44 000
HZ - HC - PC - PZ	120 000	60 000

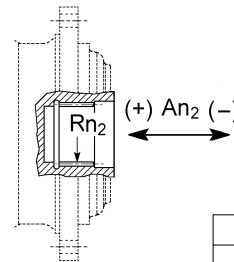

	Rn ₂	An ₂ (+/-)
FZ	35 000	35 000

Fattore f_{h2} correttivo per carichi sugli alberi Load corrective factor f_{h2} on shafts Korrektionsfaktor f_{h2} für wellenbelastungen Facteur de correction f_{h2} pour charges sur les arbres	$F_{h2} = n_2 \cdot h$						
		10 000	25 000	50 000	100 000	500 000	1 000 000
	f_{h2}	MZ - MC - FZ	1	0.74	0.58	0.46	0.27
	HZ - HC - PC - PZ	1	0.76	0.61	0.50	0.31	0.25

Carichi radiali ammissibili sull'albero veloce per un valore di $F_{h1} : n_1 \cdot h = 250\ 000$

Permissible radial loads on input shaft with $F_{h1} : n_1 \cdot h = 250\ 000$

An der Antriebswelle zulässige Radiallasten für einen Wert von $F_{h1} : n_1 \cdot h = 250\ 000$

Charges radiales admises sur l'arbre d'entrée pour une valeur de $F_{h1} : n_1 \cdot h = 250\ 000$

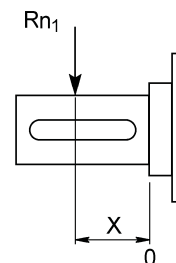
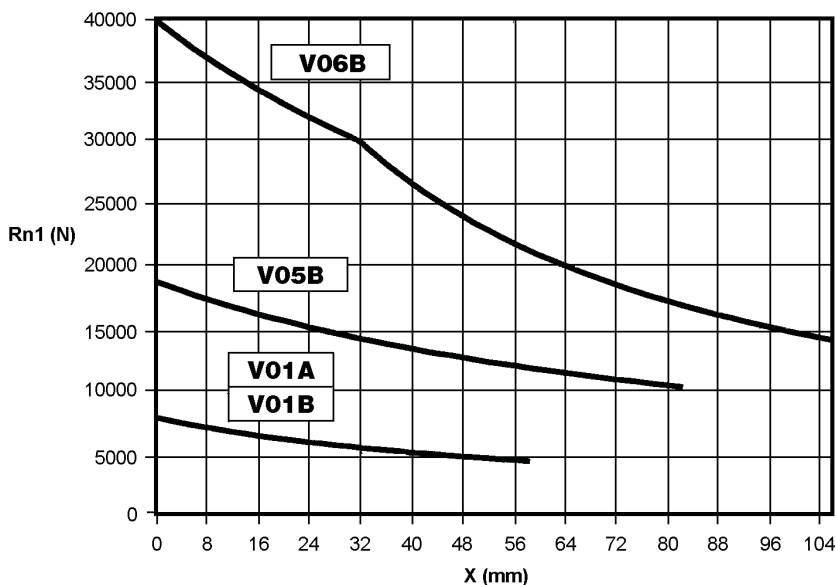

Fattore f_{h1} correttivo per carichi sugli alberi Load corrective factor f_{h1} on shafts Korrektionsfaktor f_{h1} für wellenbelastungen Facteur de correction f_{h1} pour charges sur les arbres	$F_{h1} = n_1 \cdot h$						
		250 000	500 000	1 000 000	2 000 000	5 000 000	10 000 000
f_{h1}		1	0.79	0.63	0.50	0.37	0.29