



305L



M₂ = 5000 Nm

	i	M _{n2} [Nm]						P ₁	P _t	n ₁	n _{1max}	M _b	
		n ₂ ·h	n ₂ ·h	n ₂ ·h	n ₂ ·h	n ₂ ·h	n ₂ ·h						
	1:	10 000	25 000	50 000	100 000	500 000	1 000 000						
L1	3.60	4 700	4 450	4 300	4 200	3 750	3 050	60	13	1 800	3 800	1 000	5K
	4.25	5 800	5 500	5 300	5 200	3 700	3 000	60	13	1 800	3 800	1 000	5K
	5.33	5 600	4 900	4 400	4 400	3 600	2 950	60	13	1 800	3 800	1 000	5K
	6.20	4 600	3 950	3 600	3 600	3 550	2 900	60	13	1 800	3 800	800	5G
	7.50	3 800	3 300	3 100	3 100	3 000	2 400	60	13	1 800	3 800	630	5E
L2	12.5	4 700	4 450	4 300	4 200	3 250	2 650	30	9	2 000	4 000	400	4K
	15.3	4 700	4 450	4 300	4 200	3 250	2 650	30	9	2 000	4 000	330	4H
	18.1	5 800	5 500	5 300	5 200	3 650	2 950	30	9	2 000	4 000	400	4K
	20.8	4 700	4 450	4 300	4 200	3 100	2 500	30	9	2 000	4 000	260	4F
	22.7	5 600	4 900	4 400	4 400	3 600	2 950	30	9	2 000	4 000	330	4H
	24.5	5 500	5 400	5 300	5 200	3 450	2 800	30	9	2 000	4 000	330	4H
	26.4	4 600	3 950	3 600	3 600	3 550	2 900	23	9	2 000	4 000	260	4F
	30.8	5 600	4 900	4 400	4 400	3 600	2 950	24	9	2 000	4 000	260	4F
	35.8	4 600	3 950	3 600	3 600	3 550	2 900	17.0	9	2 000	4 000	160	4D
	38.4	5 600	4 900	4 400	4 400	3 600	2 900	19.8	9	2 000	4 000	160	4D
	44.6	4 600	3 950	3 600	3 600	3 550	2 900	14.1	9	2 000	4 000	160	4D
	54.0	3 800	3 300	3 100	3 100	3 000	2 400	10.0	9	2 000	4 000	100	4B
L3	43.6	4 700	4 450	4 300	4 200	3 250	2 650	17.3	7.5	2 000	4 000	160	4D
	53.4	4 700	4 450	4 300	4 200	3 250	2 650	14.3	7.5	2 000	4 000	160	4D
	63.1	5 800	5 350	5 300	5 200	3 650	3 000	14.6	7.5	2 000	4 000	160	4D
	72.3	4 700	4 450	4 300	4 200	3 250	2 650	10.7	7.5	2 000	4 000	100	4B
	77.2	5 800	5 500	5 300	5 200	3 650	2 950	12.5	7.5	2 000	4 000	100	4B
	90.2	4 700	4 450	4 300	4 200	3 250	2 650	8.7	7.5	2 000	4 000	100	4B
	105	5 800	5 500	5 300	5 200	3 650	2 950	9.4	7.5	2 000	4 000	100	4B
	113	4 600	3 950	3 600	3 600	3 550	2 900	6.7	7.5	2 000	4 000	100	4B
	124	4 600	3 950	3 600	3 600	3 550	2 900	6.2	7.5	2 000	4 000	50	4A
	141	5 500	5 350	5 300	5 200	3 450	2 800	6.6	7.5	2 000	4 000	100	4B
	152	4 600	3 950	3 600	3 600	3 550	2 900	5.2	7.5	2 000	4 000	50	4A
	164	5 600	4 900	4 400	4 400	3 600	2 950	6.0	7.5	2 000	4 000	50	4A
	178	5 600	4 900	4 400	4 400	3 600	2 950	5.6	7.5	2 000	4 000	50	4A
	190	4 600	3 950	3 600	3 600	3 550	2 900	4.3	7.5	2 000	4 000	50	4A
	220	4 750	4 750	4 750	4 750	3 050	2 500	3.7	7.5	2 000	4 000	50	4A
	258	4 600	3 950	3 600	3 600	3 550	2 900	3.4	7.5	2 000	4 000	50	4A
276	5 600	4 900	4 400	4 400	3 600	2 900	3.7	7.5	2 000	4 000	50	4A	
312	3 800	3 300	3 100	3 100	3 000	2 400	2.4	7.5	2 000	4 000	50	4A	
389	3 800	3 300	3 100	3 100	3 000	2 400	2.0	7.5	2 000	4 000	50	4A	
L4	413	5 600	4 900	4 400	4 400	3 600	2 900	4.0	6	2 000	4 000	50	4A
	446	5 800	5 500	5 300	5 200	3 650	2 950	4.0	6	2 000	4 000	50	4A
	492	5 500	5 350	5 300	5 200	3 450	2 800	3.2	6	2 000	4 000	50	4A
	556	5 800	5 500	5 300	5 200	3 650	2 950	3.2	6	2 000	4 000	50	4A
	649	4 700	4 450	4 300	4 200	3 250	2 650	2.2	6	2 000	4 000	50	4A
	718	4 600	3 950	3 600	3 600	3 550	2 900	2.2	6	2 000	4 000	50	4A
	816	5 500	5 350	5 300	5 200	3 450	2 800	2.2	6	2 000	4 000	50	4A
	896	4 600	3 950	3 600	3 600	3 550	2 900	1.9	6	2 000	4 000	50	4A
	1 018	5 500	5 350	5 300	5 200	3 450	2 800	1.7	6	2 000	4 000	50	4A
	1 098	4 600	3 950	3 600	3 600	3 550	2 900	1.6	6	2 000	4 000	50	4A
	1 278	5 600	4 900	4 400	4 400	3 600	2 950	1.4	6	2 000	4 000	50	4A
	1 370	4 600	3 950	3 600	3 600	3 550	2 900	1.3	6	2 000	4 000	50	4A
	1 586	4 750	4 750	4 750	4 750	3 050	2 500	0.88	6	2 000	4 000	50	4A
	1 854	4 600	3 950	3 600	3 600	3 550	2 900	0.96	6	2 000	4 000	50	4A
	1 991	5 600	4 900	4 400	4 400	3 600	2 900	0.88	6	2 000	4 000	50	4A
2 243	3 800	3 300	3 100	3 100	3 000	2 400	0.71	6	2 000	4 000	50	4A	
2 799	3 800	3 300	3 100	3 100	3 000	2 400	0.59	6	2 000	4 000	50	4A	

M_{2max} = 1.2 · M_{n2} (n₂ · h = 10 000)

M₂ = 5000 Nm

305R

	i	M _{n2} [Nm]						P ₁ [kW]	P _t [kW]	n ₁ [min ⁻¹]	n _{1max} [min ⁻¹]	M _b [Nm]	
		n ₂ ·h 10 000	n ₂ ·h 25 000	n ₂ ·h 50 000	n ₂ ·h 100 000	n ₂ ·h 500 000	n ₂ ·h 1 000 000						
R2	9.23	4 650	4 050	3 600	3 200	2 000	1 600	35	18	1 800	3 800	440	4L
	10.9	5 300	4 650	4 150	3 600	2 200	1 800	35	18	1 800	3 800	440	4L
	13.7	5 600	4 900	4 400	4 200	2 600	2 100	35	18	1 800	3 800	440	4L
	15.9	4 600	3 950	3 600	3 600	2 900	2 350	35	18	1 800	3 800	330	4H
	19.2	3 800	3 300	3 100	3 100	3 000	2 400	27	18	1 800	3 800	260	4F
R3	25.7	4 150	4 150	4 150	4 150	2 600	2 100	15.0	14	2 000	4 000	260	4F
	31.5	4 700	4 450	4 300	4 200	3 000	2 450	15.0	14	2 000	4 000	260	4F
	37.1	5 800	5 500	5 300	5 200	3 400	2 750	15.0	14	2 000	4 000	260	4F
	42.6	4 700	4 450	4 300	4 200	3 100	2 500	15.0	14	2 000	4 000	160	4D
	46.6	5 600	4 900	4 400	4 400	3 600	2 950	15.0	14	2 000	4 000	160	4D
	50.3	5 500	5 350	5 300	5 200	3 450	2 800	15.0	14	2 000	4 000	160	4D
	54.2	4 600	3 950	3 600	3 600	3 550	2 900	12.4	14	2 000	4 000	100	4B
	63.1	5 600	4 900	4 400	4 400	3 600	2 950	13.4	14	2 000	4 000	100	4B
	73.3	4 600	3 950	3 600	3 600	3 550	2 900	9.6	14	2 000	4 000	100	4B
	78.7	5 600	4 900	4 400	4 400	3 600	2 900	11.1	14	2 000	4 000	100	4B
	91.5	4 600	3 950	3 600	3 600	3 550	2 900	8.0	14	2 000	4 000	100	4B
	111	3 800	3 300	3 100	3 100	3 000	2 400	5.6	14	2 000	4 000	50	4A
R4	129	5 800	5 400	5 300	5 200	3 650	3 000	12.3	12	2 000	4 000	50	4A
	148	4 700	4 450	4 300	4 200	3 250	2 650	9.1	12	2 000	4 000	50	4A
	158	5 800	5 500	5 300	5 200	3 650	2 950	10.6	12	2 000	4 000	50	4A
	185	4 700	4 450	4 300	4 200	3 250	2 650	7.4	12	2 000	4 000	50	4A
	214	5 800	5 500	5 300	5 200	3 650	2 950	7.9	12	2 000	4 000	50	4A
	231	4 600	3 950	3 600	3 600	3 550	2 900	5.8	12	2 000	4 000	50	4A
	255	4 600	3 950	3 600	3 600	3 550	2 900	5.3	12	2 000	4 000	50	4A
	290	5 500	5 400	5 300	5 200	3 450	2 800	5.7	12	2 000	4 000	50	4A
	313	4 600	3 950	3 600	3 600	3 550	2 900	4.5	12	2 000	4 000	50	4A
	336	5 600	4 900	4 400	4 400	3 600	2 900	4.9	12	2 000	4 000	50	4A
	364	5 600	4 900	4 400	4 400	3 600	2 950	4.8	12	2 000	4 000	50	4A
	390	4 600	3 950	3 600	3 600	3 550	2 900	3.7	12	2 000	4 000	50	4A
	452	4 750	4 750	4 750	4 750	3 050	2 500	3.1	12	2 000	4 000	50	4A
	528	4 600	3 950	3 600	3 600	3 550	2 900	2.5	12	2 000	4 000	50	4A
	567	5 600	4 900	4 400	4 400	3 600	2 900	3.1	12	2 000	4 000	50	4A
	639	3 800	3 300	3 100	3 100	3 000	2 400	2.0	12	2 000	4 000	50	4A
797	3 800	3 300	3 100	3 100	3 000	2 400	1.7	12	2 000	4 000	50	4A	

M_{2max} = 1.2 · M_{n2} (n₂ · h = 10 000)

305L

		Motore idraulico / Hydraulic motor Hydraulikmotor/Moteur hydraulique										Kg
		MG							201			
cm ³	50	80	100	125	160	200	250	M2	M3	M4		
	M1	M1	M1	M1	M1	M1	M1	M2	M3	M4		
305L1	-	-	-	-	199	206	215	135	77	1/4G	20	
305L2	156	162	166	170	177	184	-	113	60	1/4G	14	

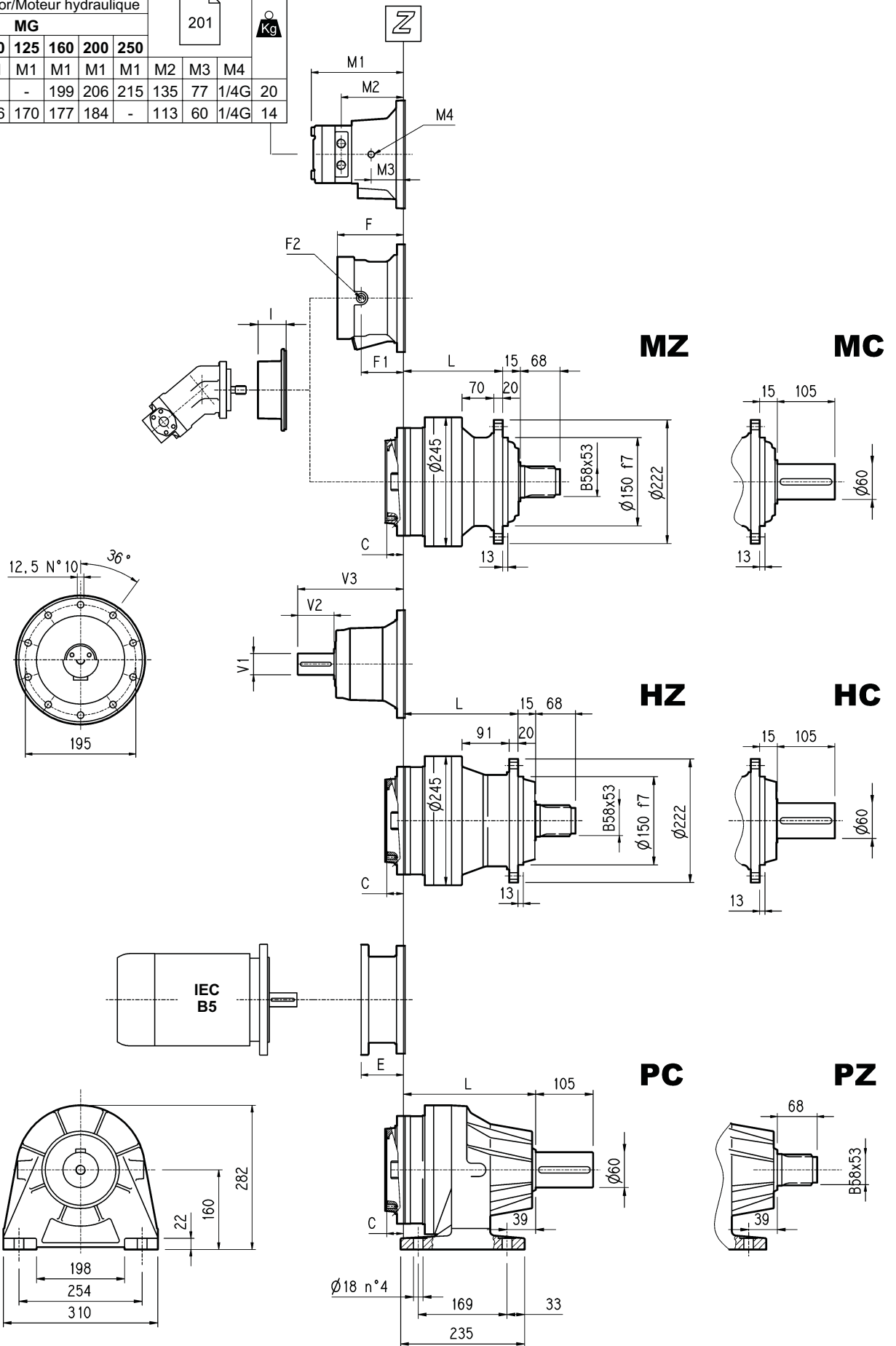

305R

		Motore idraulico / Hydraulic motor Hydraulikmotor/Moteur hydraulique						201			Kg
		MG									
cm ³	50	80	100	125	160	200	250	M1	M2	M3	M4
	M1	M1	M1	M1	M1	M1	M1	M2	M3	M4	
305R2	156	162	166	170	177	184	-	113	60	1/4G	14

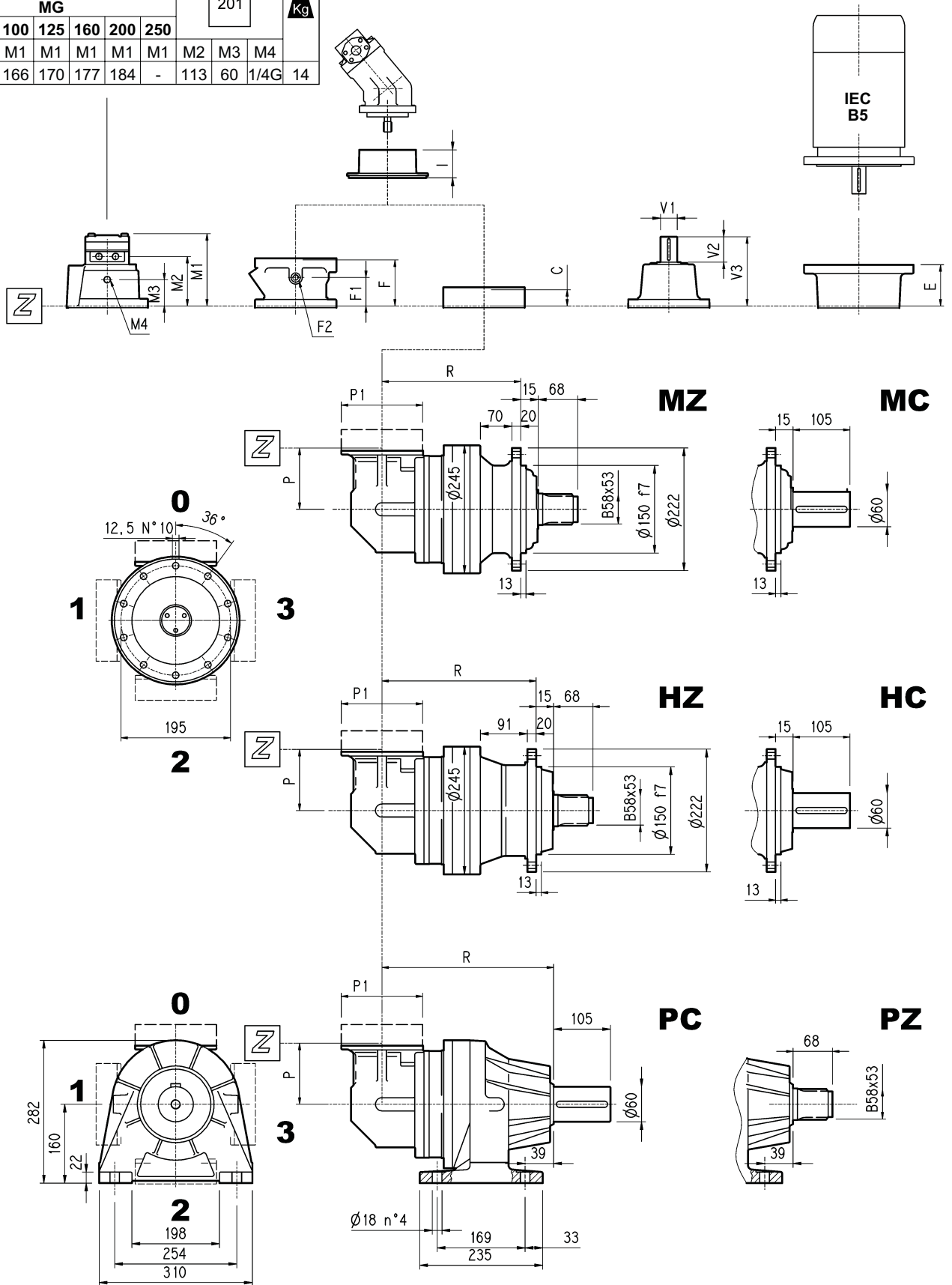

305R

		Motore idraulico / Hydraulic motor Hydraulikmotor/Moteur hydraulique							201			
		MG										
cm³	50	80	100	125	160	200	250	M2	M3	M4		
	M1	M1	M1	M1	M1	M1	M1					
305R2	156	162	166	170	177	184	-	113	60	1/4G	14	

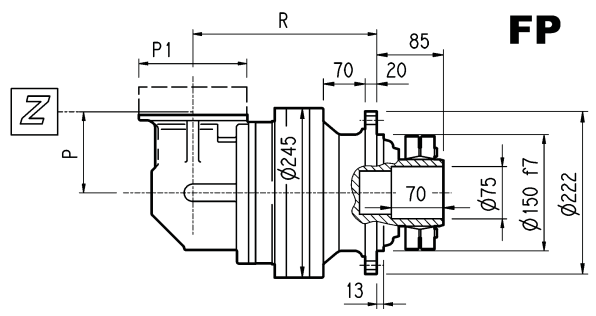
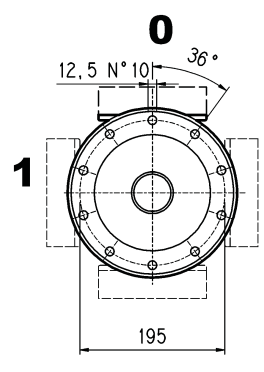
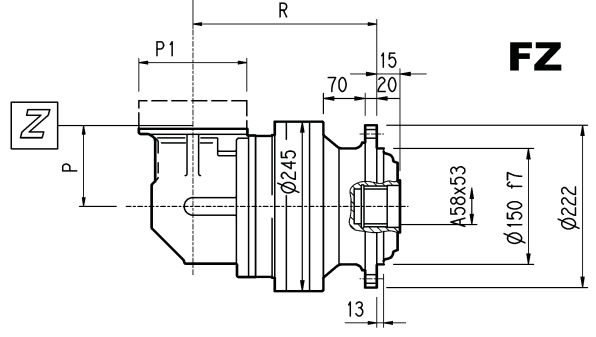
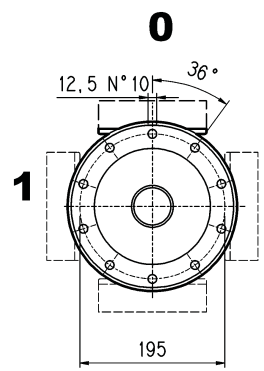
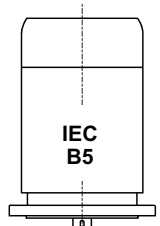
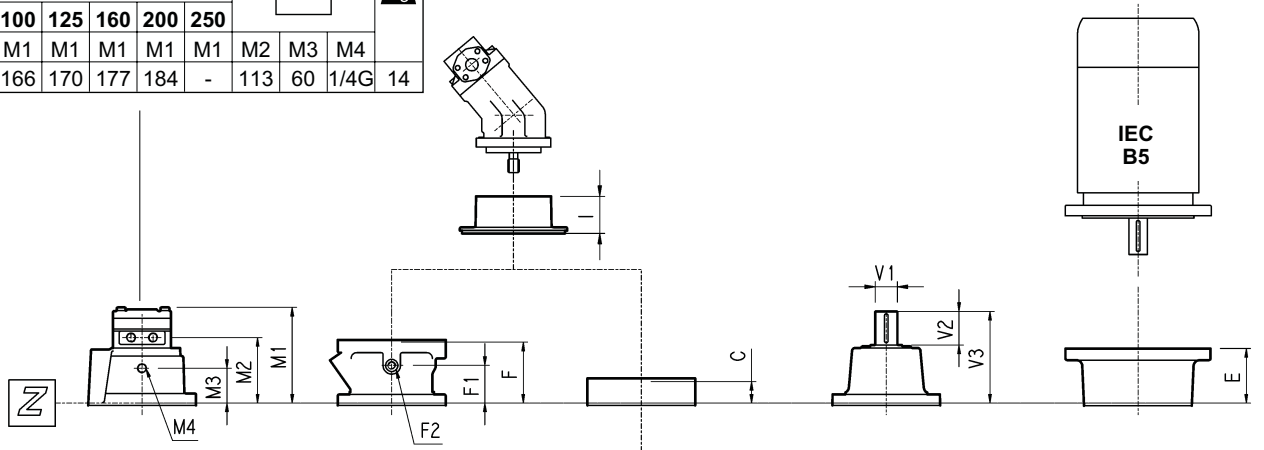

VERSIONE FP FP VERSION VERSION FP VERSION FP	COPPIA MAX. TRASMISSIBILE MAX. TRANSMISSIBLE TORQUE MAX. ÜBERTR. MOMENT COUPLE MAX. TRANSMISSIBLE	7 000 Nm
---	--	-----------------

	R				P	P1					C	Entrata Input Antrieb Entrée	I	F	F1	F2	Tipo Type Typ Type	Entrata Input Antrieb Entrée	
	MZ MC	FZ FP	HZ HC	PC PZ			MZ MC	FZ FP	HZ HC	PC PZ									
305 R2	235	235	260	275	140	186	56	56	60	65	37	A	105	65	1/4 G	4	A	10	
305 R3	300	300	325	340	122	186	57	57	61	66	37	A	105	65	1/4 G	4	A	10	
305 R4	353	353	378	393	122	186	61	61	65	70	37	A	191	105	65	1/4 G	4	A	10

	V1	V2	V3		V1	V2	V3		E						
									IEC 71	IEC 80	IEC 90	IEC 100	IEC 112	IEC 132	
305 R2	24	36	137.5	6	38	58	158	7	65	84	84	94	94	114	
305 R3	24	36	137.5	6	38	58	158	7	65	84	84	94	94	114	
305 R4	24	36	137.5	6	38	58	158	7	65	84	84	94	94	114	

305L - 305R

MC-HC

PC

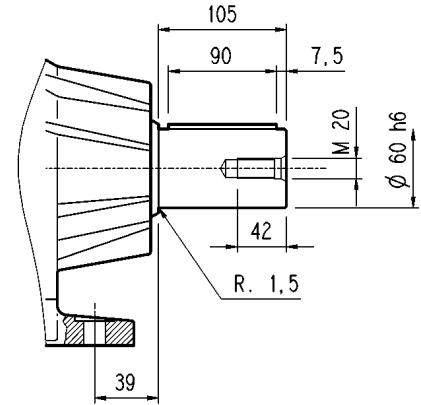
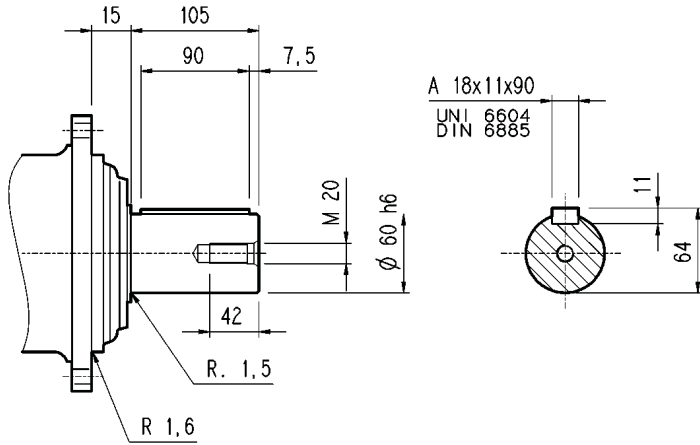

MZ-HZ

FZ

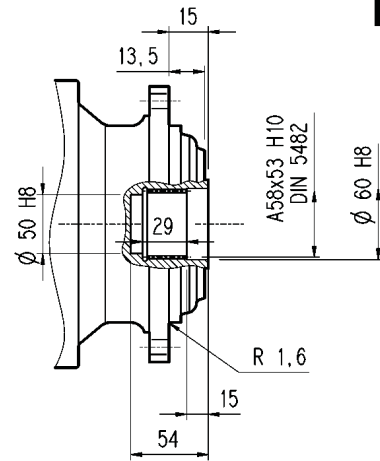
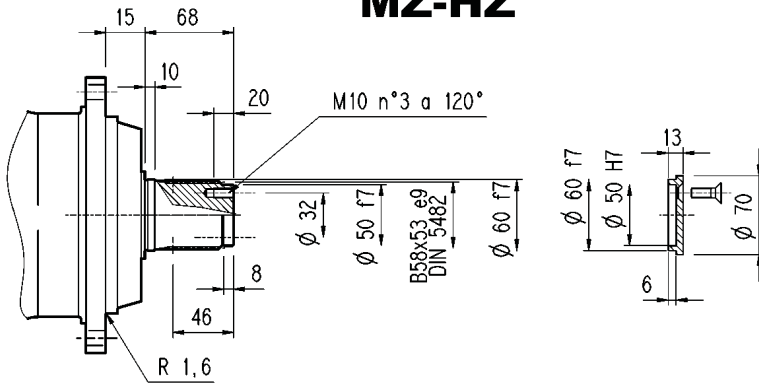

FP

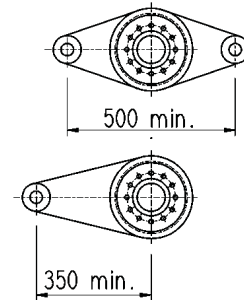
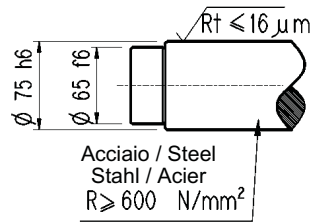
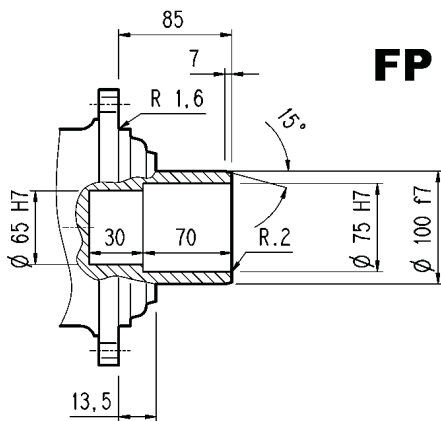

VERSIONE FP	COPPIA MAX. TRASMISSIBILE	7 000 Nm
FP VERSION	MAX. TRANSMISSIBLE TORQUE	
VERSION FP	MAX. ÜBERTR. MOMENT	
VERSION FP	COUPLE MAX. TRANSMISSIBLE	

Flangia / Flange
Flansch / Brides

305L - 305R

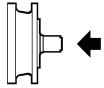

WOA

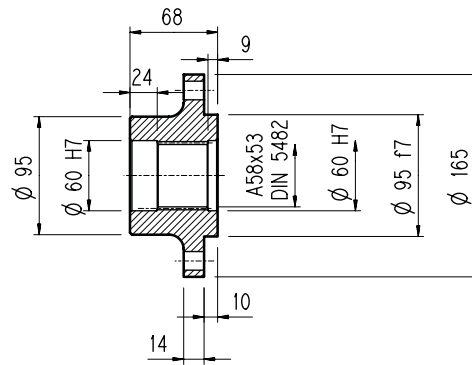
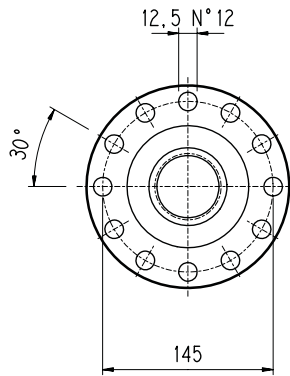

Materiale : Acciaio C40
Material : Steel C40
Material : Stahl C40
Màterial : Acier C40

Pignoni per rotazione / Output pinions
Ritzel / Pignons

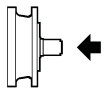

P...

Codice Code	m	z	x	dp	di	de	H	A	B	C	★
PCL1	5	19	0	95	82	104	77	12	9	72	■
PCL2	5	19	0	95	82	104	68	0	0	0	■
PCM	5	20	0	100	87.5	110	68	18	0	0	□
PCP	5	22	0	110	97.5	120	68	18	0	0	□
PDE	6	14	0.500	84	75	99.6	68	0	0	0	■
PDI	6	18	0.500	108	99	123.6	68	0	0	0	■
PDM	6	20	0.833	120	115	140	68	0	0	0	■
PFD	8	13	0.675	104	95	127.6	68	0	0	0	□
PFE1	8	14	0	112	92	126	68	0	0	0	□
PFE2	8	14	0	112	92	126	80	0	12	72	□
PFF	8	15	0	120	100	136	68	0	0	0	■
PFP	8	22	0	176	156	190	77	12	10	71	■
PHG	10	16	0.500	160	145	188	75	0	7	72	■

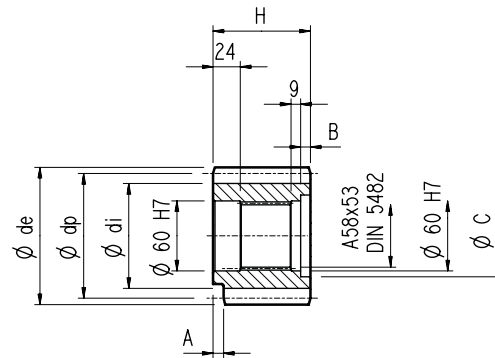

★	Materiale/Material/Material/Màterial
■	Acciaio 39NiCrMo3 Bonificato Steel 39NiCrMo3 hardened and tempered Vergüteter Stahl 39NiCrMo3 Acier bonifié 39NiCrMo3
□	Acciaio 18NiCrMo5 Cementato e temprato Steel 18NiCrMo5 Case hardened Einsatzstahl 18NiCrMo5 Einsatzgehärtet Acier cementé et tempré 18NiCrMo5

Manicotti lisci / Sleeve couplings
Naben / Manchons lisses a cannelure interieure

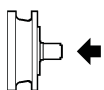

MOA

Materiale : Acciaio 16CrNi4
Material : Steel 16CrNi4
Material : Stahl 16CrNi4
Màterial : Acier 16CrNi4

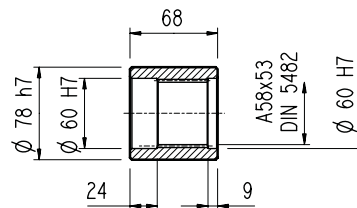

Barre scanalate / Splined bars
Vielkeilwellen / Barre cannelée

B0A

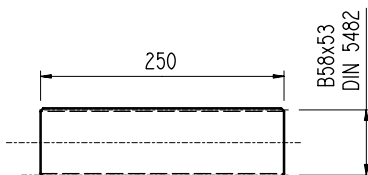
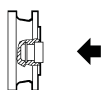

Mat. acciaio 18NiCrMo5 UNI 5331 da cementare e temprare 50-55 HRC
Case hardening steel 18NiCrMo5 UNI 5331
must be case hardened 50-55 HRC
Material: Einsatzstahl 18NiCrMo5 UNI 5331
muss einsatzgehärtet werden 50-55 HRC
Acier 18 NiCrMo5 UNI 5331 doit être cémenté trempé 50-55 HRC

Giunto ad attrito / Shrink disc
Schrumpfscheibe / Frette de serrage

G0A

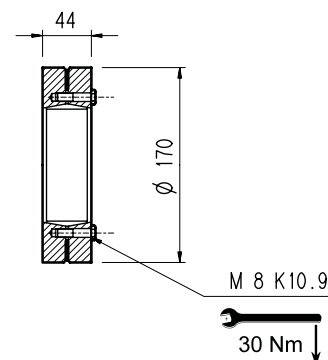
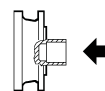

305L - 305R

Alberi veloci / Input shaft
Antriebswellen / Arbres d'entrée

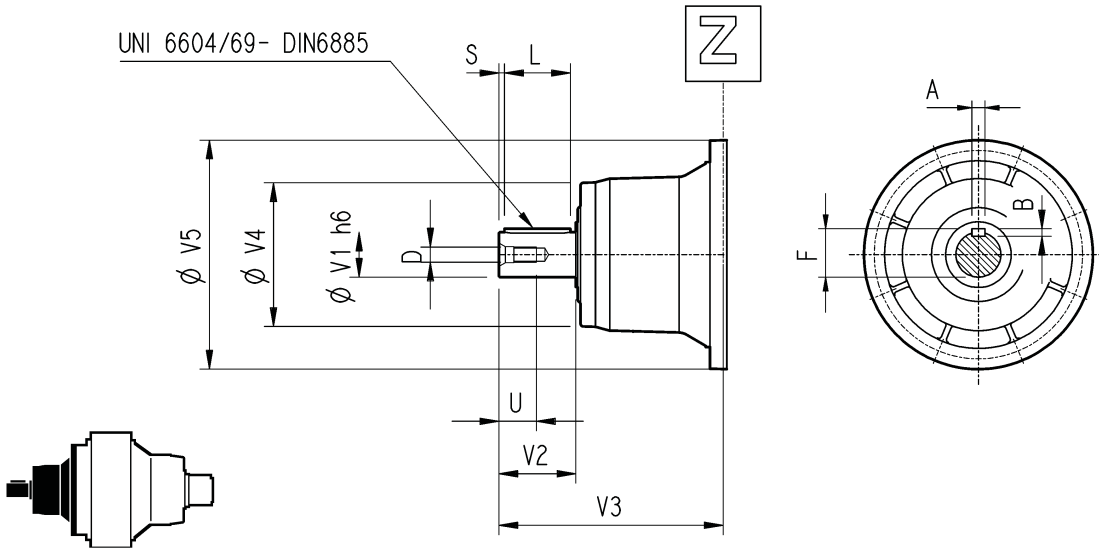

	CODE	V1	V2	V3	V4	V5	A	B	F	L	S	D	U
305 L1	V05B	48	82	239	155	245	14	9	51.5	70	6	M16	36
305 L2	V01A	24	36	137.5	120	186	8	7	27	30	3	M8	19
	V01B	38	58	158	120	186	10	8	41	50	4	M12	28
305 L3	V01A	24	36	137.5	120	186	8	7	27	30	3	M8	19
	V01B	38	58	158	120	186	10	8	41	50	4	M12	28
305 L4	V01A	24	36	137.5	120	186	8	7	27	30	3	M8	19
	V01B	38	58	158	120	186	10	8	41	50	4	M12	28
305 R2-R3-R4	V01A	24	36	137.5	120	186	8	7	27	30	3	M8	19
	V01B	38	58	158	120	186	10	8	41	50	4	M12	28

Dimensioni d'entrata senza predisposizione motore
Input dimension without motor adaptor
Maße für den Antrieb ohne Motoradapter
Dimensions d'entrée sans prédisposition moteur

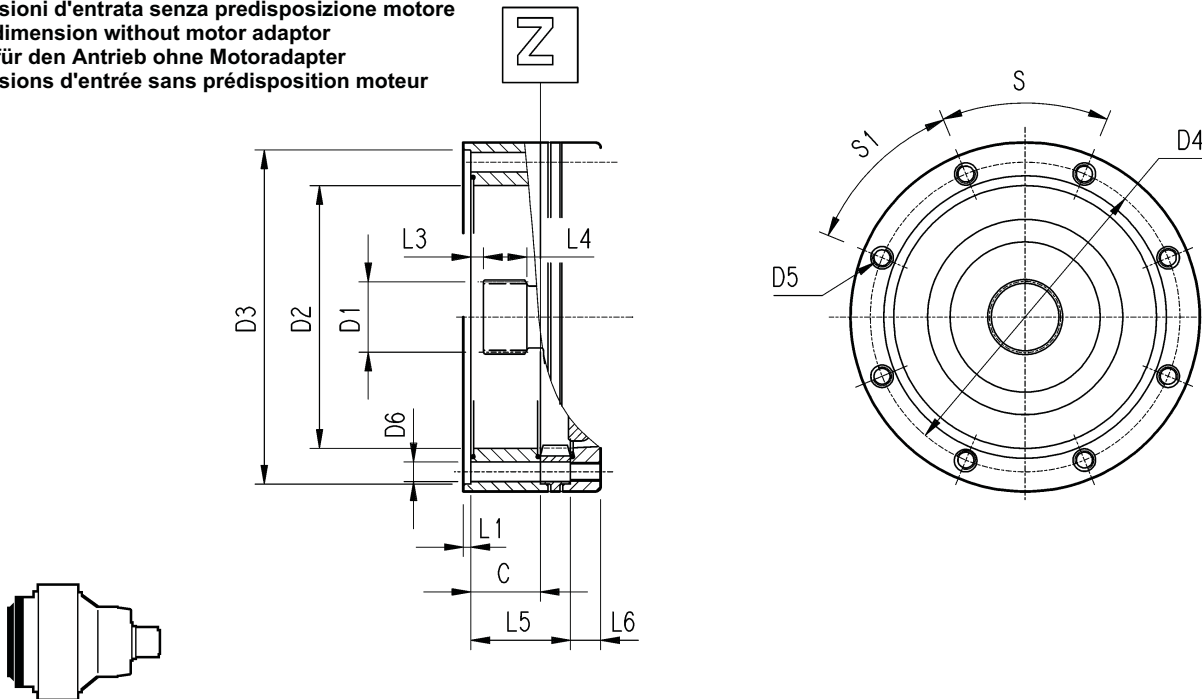

	C	D1	D2	D3	D4	D5	D6	L1	L2	L3	L4	L5	L6	S	S1	Entrata Input Antrieb Entrée
305 L1	37	40x36 DIN5482	140	178 H7	165	M10 n°8	11	4	18	9	18	0	0	45°	45°	A
305 L2	37	40x36 DIN5482	140	178 H7	165	M10 n°8	11	4	/	9	18	65	18	45°	45°	A
305 L3	37	40x36 DIN5482	140	178 H7	165	M10 n°8	11	4	/	9	18	118	18	45°	45°	A
305 L4	37	40x36 DIN5482	140	178 H7	165	M10 n°8	11	4	/	9	18	171	18	45°	45°	A
305 R2-R3-R4	37	40x36 DIN5482	140	178 H7	165	M10 n°8	11	4	/	9	18	37	18	45°	45°	A

305L - 305R

Carichi radiali ed assiali ammissibili sull'albero lento per un valore di $Fh_2 : n_2 \cdot h = 10\ 000$

Permissible radial and axial loads on output shaft with $Fh_2 : n_2 \cdot h = 10\ 000$

An der Ausgangswelle zulässige Radiallasten und Axialkräfte für einen Wert von $Fh_2 : n_2 \cdot h = 10\ 000$

Charges radiales et axiales admissibles sur l'arbre lent pour une valeur de $Fh_2 : n_2 \cdot h = 10\ 000$

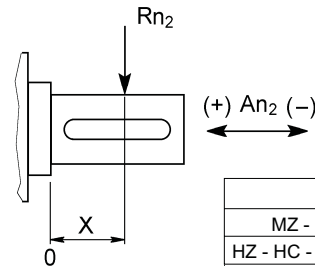
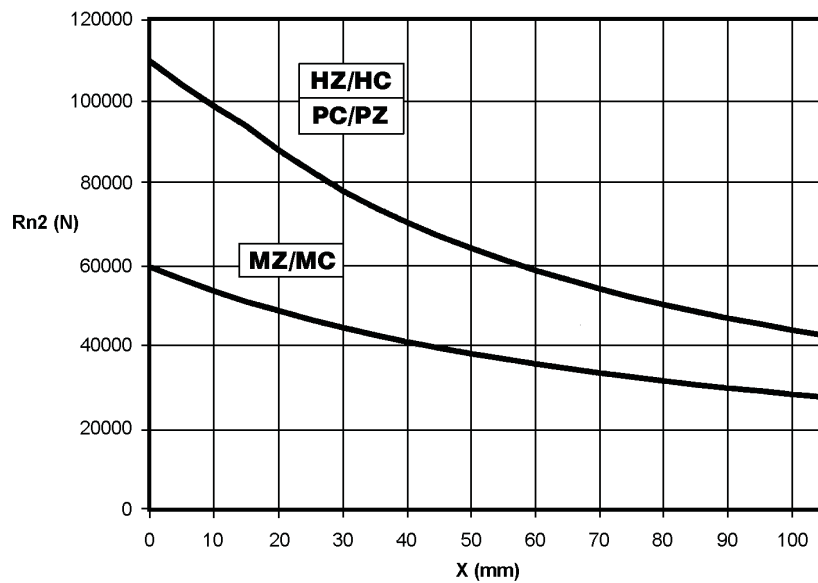

	An ₂ (+)	An ₂ (-)
MZ - MC	55 000	44 000
HZ - HC - PC - PZ	55 000	44 000

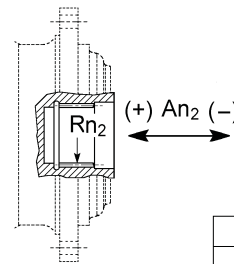

	Rn ₂	An ₂ (+/-)
FZ	24 000	25000

Fattore fh ₂ correttivo per carichi sugli alberi Load corrective factor fh ₂ on shafts Korrektionsfaktor fh ₂ für wellenbelastungen Facteur de correction fh ₂ pour charges sur les arbres	Fh ₂ = n ₂ · h						
		10 000	25 000	50 000	100 000	500 000	1 000 000
fh ₂	MZ - MC - FZ	1	0.74	0.58	0.46	0.27	0.21
	HZ - HC - PC - PZ	1	0.76	0.61	0.50	0.31	0.25

Carichi radiali ammissibili sull'albero veloce per un valore di $Fh_1 : n_1 \cdot h = 250\ 000$

Permissible radial loads on input shaft with $Fh_1 : n_1 \cdot h = 250\ 000$

An der Antriebswelle zulässige Radiallasten für einen Wert von $Fh_1 : n_1 \cdot h = 250\ 000$

Charges radiales admises sur l'arbre d'entrée pour une valeur de $Fh_1 : n_1 \cdot h = 250\ 000$

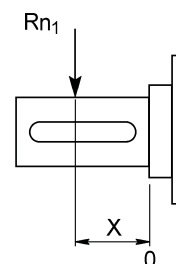
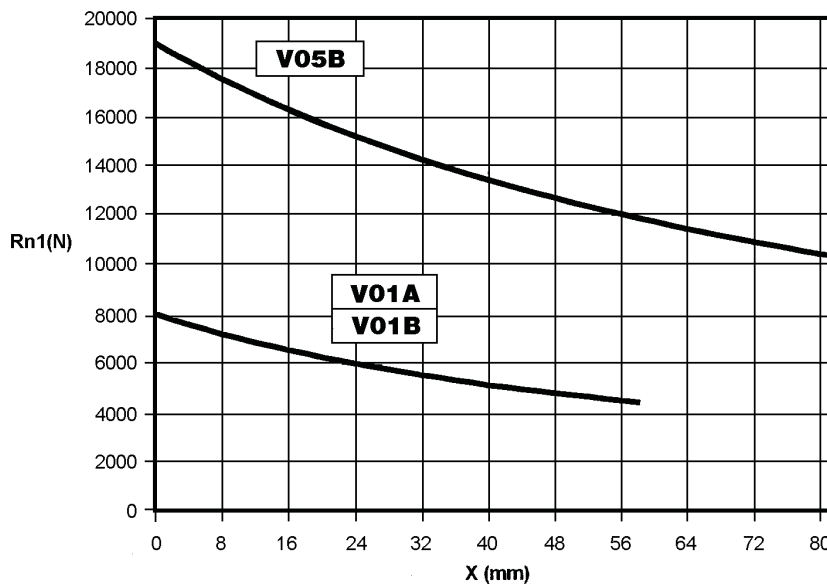

Fattore fh ₁ correttivo per carichi sugli alberi Load corrective factor fh ₁ on shafts Korrektionsfaktor fh ₁ für wellenbelastungen Facteur de correction fh ₁ pour charges sur les arbres	Fh ₁ = n ₁ · h						
		250 000	500 000	1 000 000	2 000 000	5 000 000	10 000 000
fh ₁	1	0.79	0.63	0.50	0.37	0.29	