





**300L**
**M<sub>2</sub> = 1000 Nm**

	i	M <sub>n2</sub> [Nm]						P <sub>1</sub>	P <sub>t</sub>	n <sub>1</sub>	n <sub>1max</sub>	M <sub>b</sub>	
		n <sub>2</sub> ·h	n <sub>2</sub> ·h	n <sub>2</sub> ·h	n <sub>2</sub> ·h	n <sub>2</sub> ·h	n <sub>2</sub> ·h						
1:	10 000	25 000	50 000	100 000	500 000	1 000 000							
<b>L1</b>	3.48	700	700	700	650	650	640	20	7.5	2 000	4 000	260	4F
	4.26	1 000	1 000	890	850	760	610	20	7.5	2 000	4 000	330	4H
	5.77	860	730	650	650	650	580	18.2	7.5	2 000	4 000	260	4F
	7.20	700	600	550	550	550	510	12.4	7.5	2 000	4 000	160	4D
<b>L2</b>	12.1	700	700	700	650	650	640	9.0	7.5	2 000	4 000	100	4B
	14.8	700	700	700	650	650	640	7.3	7.5	2 000	4 000	100	4B
	18.2	1 000	1 000	890	850	760	610	7.8	7.5	2 000	4 000	100	4B
	20.1	700	700	700	650	650	640	5.4	7.5	2 000	4 000	100	4B
	24.6	1 000	1 000	890	850	760	610	5.8	7.5	2 000	4 000	100	4B
	30.7	1 000	1 000	890	850	760	610	4.9	7.5	2 000	4 000	50	4A
	33.3	860	730	650	650	650	580	3.3	7.5	2 000	4 000	50	4A
	41.5	860	730	650	650	650	580	2.8	7.5	2 000	4 000	50	4A
	51.8	700	600	550	550	550	510	1.9	7.5	2 000	4 000	50	4A
<b>L3</b>	42.1	700	700	700	650	650	640	2.9	7.5	2 000	4 000	50	4A
	51.6	1 000	1 000	890	850	760	610	3.2	7.5	2 000	4 000	50	4A
	63.2	1 000	1 000	890	850	760	610	2.7	7.5	2 000	4 000	50	4A
	69.9	700	700	700	650	650	640	1.7	7.5	2 000	4 000	50	4A
	77.5	1 000	1 000	890	850	760	610	2.2	7.5	2 000	4 000	50	4A
	85.6	1 000	1 000	890	850	760	610	2.0	7.5	2 000	4 000	50	4A
	105	1 000	1 000	890	850	760	610	1.6	7.5	2 000	4 000	50	4A
	116	860	730	650	650	650	580	1.2	7.5	2 000	4 000	50	4A
	131	1 000	1 000	890	850	760	610	1.3	7.5	2 000	4 000	50	4A
	142	1 000	1 000	890	850	760	610	1.2	7.5	2 000	4 000	50	4A
	177	1 000	1 000	890	850	760	610	0.97	7.5	2 000	4 000	50	4A
	192	860	730	650	650	650	580	0.80	7.5	2 000	4 000	50	4A
	221	1 000	1 000	890	850	760	610	0.78	7.5	2 000	4 000	50	4A
	240	860	730	650	650	650	580	0.67	7.5	2 000	4 000	50	4A
	299	860	730	650	650	650	580	0.56	7.5	2 000	4 000	50	4A
373	700	600	550	550	550	510	0.38	7.5	2 000	4 000	50	4A	
<b>L4</b>	403	860	730	650	650	650	580	0.63	6	2 000	4 000	50	4A
	447	1 000	1 000	890	850	760	610	0.66	6	2 000	4 000	50	4A
	494	1 000	1 000	890	850	760	610	0.60	6	2 000	4 000	50	4A
	558	1 000	1 000	890	850	760	610	0.53	6	2 000	4 000	50	4A
	616	1 000	1 000	890	850	760	610	0.48	6	2 000	4 000	50	4A
	755	1 000	1 000	890	850	760	610	0.39	6	2 000	4 000	50	4A
	819	1 000	1 000	890	850	760	610	0.36	6	2 000	4 000	50	4A
	942	1 000	1 000	890	850	760	610	0.31	6	2 000	4 000	50	4A
	1 022	1 000	1 000	890	850	760	610	0.29	6	2 000	4 000	50	4A
	1 108	860	730	650	650	650	580	0.27	6	2 000	4 000	50	4A
	1 275	1 000	1 000	890	850	760	610	0.23	6	2 000	4 000	50	4A
	1 383	860	730	650	650	650	580	0.21	6	2 000	4 000	50	4A
	1 591	1 000	1 000	890	850	760	610	0.19	6	2 000	4 000	50	4A
	1 725	860	730	650	650	650	580	0.17	6	2 000	4 000	50	4A
2 153	860	730	650	650	650	580	0.14	6	2 000	4 000	50	4A	
2 687	700	600	550	550	550	510	0.11	6	2 000	4 000	50	4A	

$$M_{2max} = 1.2 \cdot M_{n2} \quad (n_2 \cdot h = 10\,000)$$

**M<sub>2</sub> = 1000 Nm**
**300R**

	i	M <sub>n2</sub> [Nm]						P <sub>1</sub> [kW]	P <sub>t</sub> [kW]	n <sub>1</sub> [min <sup>-1</sup> ]	n <sub>1max</sub> [min <sup>-1</sup> ]	M <sub>b</sub> [Nm]	
		n <sub>2</sub> ·h 10 000	n <sub>2</sub> ·h 25 000	n <sub>2</sub> ·h 50 000	n <sub>2</sub> ·h 100 000	n <sub>2</sub> ·h 500 000	n <sub>2</sub> ·h 1 000 000						
<b>R2</b>	7.13	700	700	700	650	650	640	15.0	12	2 000	4 000	160	4D
	8.74	1 000	1 000	890	850	760	610	15.0	12	2 000	4 000	160	4D
	11.8	860	730	650	650	650	580	9.2	12	2 000	4 000	100	4B
	14.8	700	600	550	550	550	510	6.2	12	2 000	4 000	100	4B
<b>R3</b>	24.8	700	700	700	650	650	640	4.7	12	2 000	4 000	50	4A
	30.4	700	700	700	650	650	640	4.0	12	2 000	4 000	50	4A
	37.3	1 000	1 000	890	850	760	610	4.3	12	2 000	4 000	50	4A
	41.2	700	700	700	650	650	640	2.9	12	2 000	4 000	50	4A
	50.4	1 000	1 000	890	850	760	610	3.3	12	2 000	4 000	50	4A
	62.9	1 000	1 000	890	850	760	610	2.7	12	2 000	4 000	50	4A
	68.2	860	730	650	650	650	580	1.9	12	2 000	4 000	50	4A
	85.2	860	730	650	650	650	580	1.6	12	2 000	4 000	50	4A
	106	700	600	550	550	550	510	1.1	12	2 000	4 000	50	4A
<b>R4</b>	86.4	700	700	700	650	650	640	2.4	10	2 000	4 000	50	4A
	106	1 000	1 000	890	850	760	610	2.8	10	2 000	4 000	50	4A
	130	1 000	1 000	890	850	760	610	2.3	10	2 000	4 000	50	4A
	143	700	700	700	650	650	640	1.4	10	2 000	4 000	50	4A
	159	1 000	1 000	890	850	760	610	1.9	10	2 000	4 000	50	4A
	175	1 000	1 000	890	850	760	610	1.7	10	2 000	4 000	50	4A
	215	1 000	1 000	890	850	760	610	1.4	10	2 000	4 000	50	4A
	237	860	730	650	650	650	580	1.1	10	2 000	4 000	50	4A
	268	1 000	1 000	890	850	760	610	1.1	10	2 000	4 000	50	4A
	291	1 000	1 000	890	850	760	610	1.0	10	2 000	4 000	50	4A
	363	1 000	1 000	890	850	760	610	0.81	10	2 000	4 000	50	4A
	394	860	730	650	650	650	580	0.70	10	2 000	4 000	50	4A
	453	1 000	1 000	890	850	760	610	0.65	10	2 000	4 000	50	4A
	491	860	730	650	650	650	580	0.58	10	2 000	4 000	50	4A
	613	860	730	650	650	650	580	0.48	10	2 000	4 000	50	4A
765	700	600	550	550	550	510	0.33	10	2 000	4 000	50	4A	

$$M_{2max} = 1.2 \cdot M_{n2} \quad (n_2 \cdot h = 10\,000)$$

# 300L

		Motore idraulico / Hydraulic motor Hydraulikmotor/Moteur hydraulique						201			
		MG									
cm <sup>3</sup>	50	80	100	125	160	200	250	M2	M3	M4	
	M1	M1	M1	M1	M1	M1	M1	M2	M3	M4	
300L1	156	162	166	170	177	-	-	113	60	1/4G	14
300L2	156	162	166	-	-	-	-	113	60	1/4G	14

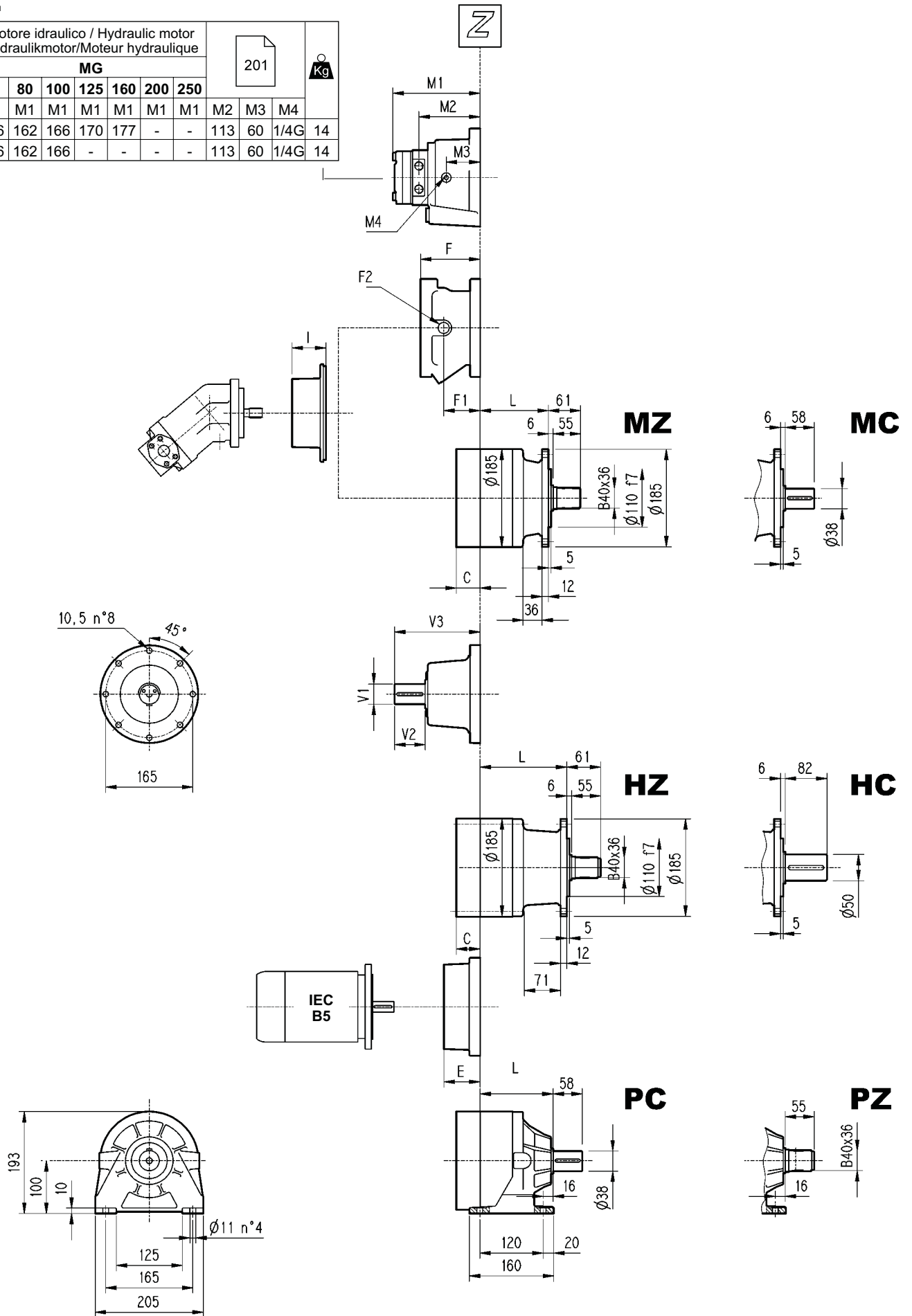

# 300L

Motore idraulico / Hydraulic motor Hydraulikmotor/Moteur hydraulique											201	
MG												
cm <sup>3</sup>	50	80	100	125	160	200	250	M2	M3	M4		
	M1	M1	M1	M1	M1	M1	M1	M2	M3	M4		
300L1	156	162	166	170	177	-	-	113	60	1/4G	14	
300L2	156	162	166	-	-	-	-	113	60	1/4G	14	

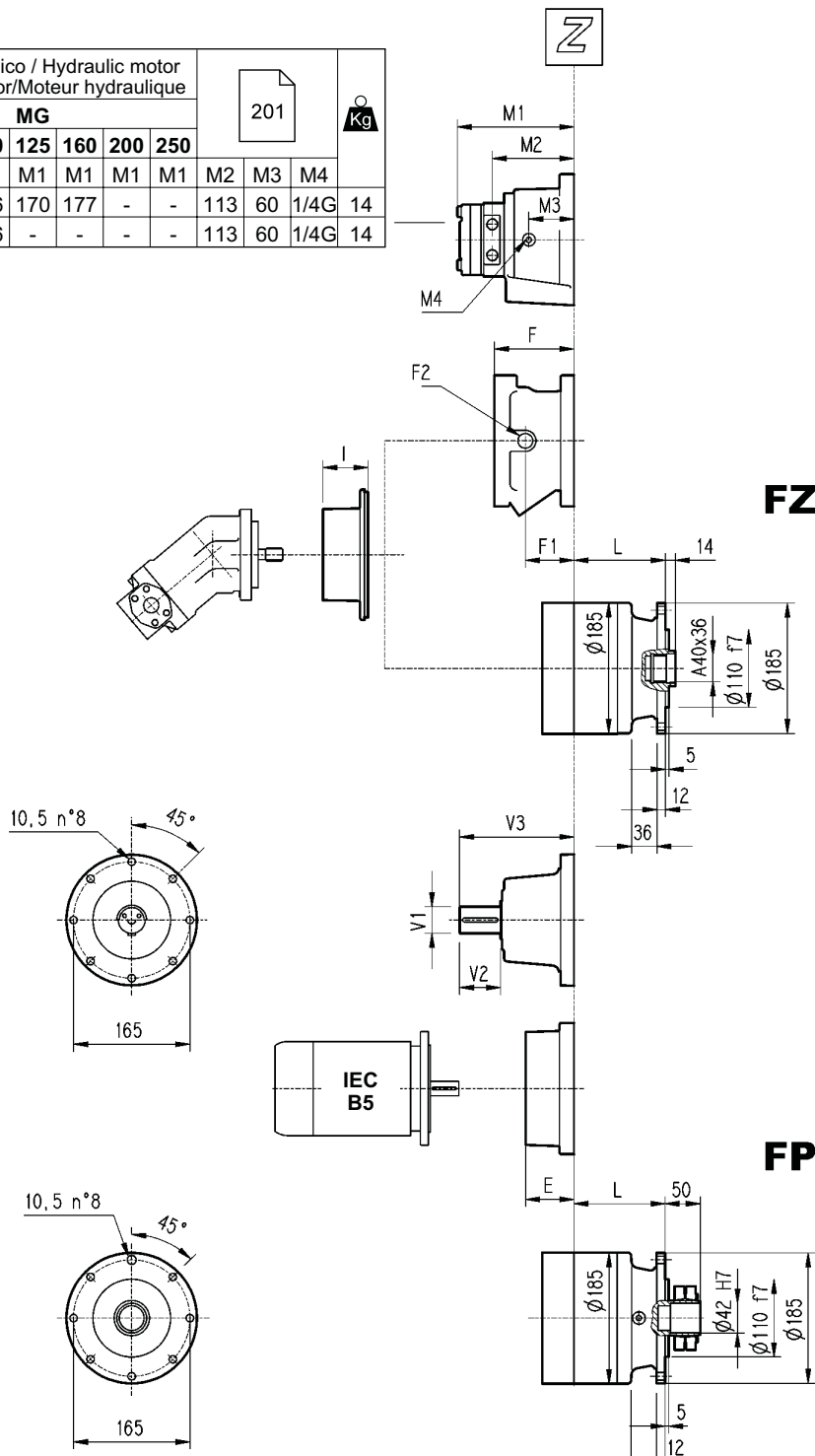

VERSIONE FP	COPPIA MAX. TRASMISSIBILE	<b>1 200 Nm</b>
FP VERSION	MAX. TRANSMISSIBLE TORQUE	
VERSION FP	MAX. ÜBERTR. MOMENT	
VERSION FP	COUPLE MAX. TRANSMISSIBLE	

	L								C	Entrata Input Antrieh Entrée	I	F	F1	F2	Tipo Type Typ Type	Entrata Input Antrieh Entrée	
	MZ MC	FZ FP	HZ HC	PC PZ	MZ MC	FZ FP	HZ HC	PC PZ									
300 L1	80	80	115	86	18	16	20	23	37	A		105	65	1/4 G	4	A	10
300 L2	133	133	168	139	22	20	24	27	37	A		105	65	1/4 G	4	A	10
300 L3	186	186	221	192	26	24	28	31	37	A		105	65	1/4 G	4	A	10
300 L4	239	239	274	245	30	28	32	35	37	A		191	105	65	1/4 G	4	A

	V1	V2	V3		V1	V2	V3		E					
									IEC 71	IEC 80	IEC 90	IEC 100	IEC 112	IEC 132
300 L1	24	36	137.5	6	38	58	158	7	65	84	84	94	94	114
300 L2	24	36	137.5	6	38	58	158	7	65	84	84	94	94	114
300 L3	24	36	137.5	6	38	58	158	7	65	84	84	94	94	114
300 L4	24	36	137.5	6	38	58	158	7	65	84	84	94	94	114

# 300R

Motore idraulico / Hydraulic motor Hydraulikmotor/Moteur hydraulique										201	
<b>MG</b>											
cm <sup>3</sup>	50	80	100	125	160	200	250	M2	M3	M4	
	M1	M1	M1	M1	M1	M1	M1	M2	M3	M4	
<b>300R2</b>	156	162	166	-	-	-	-	113	60	1/4G	14

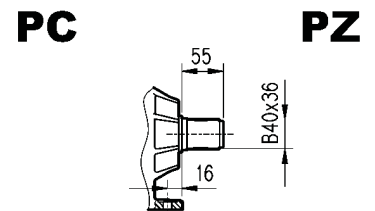
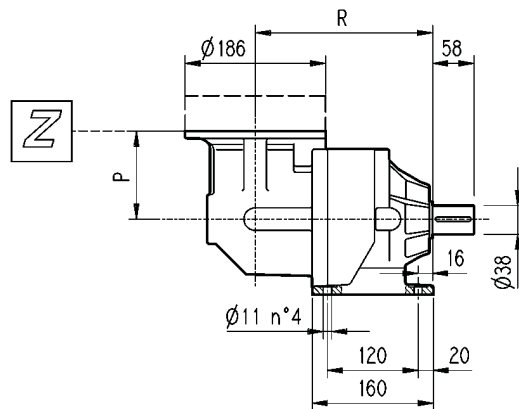
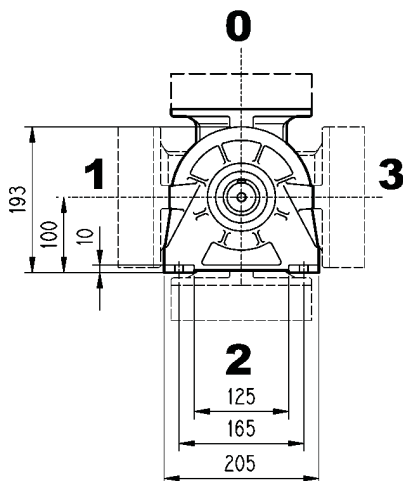
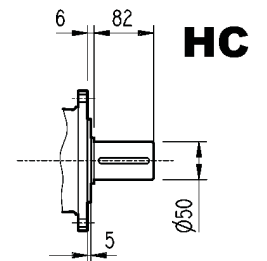
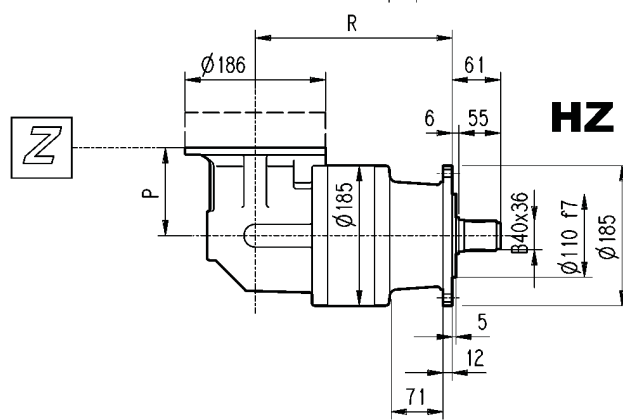
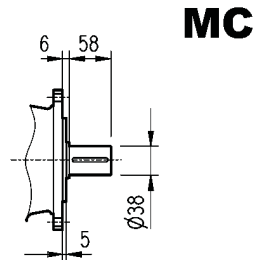
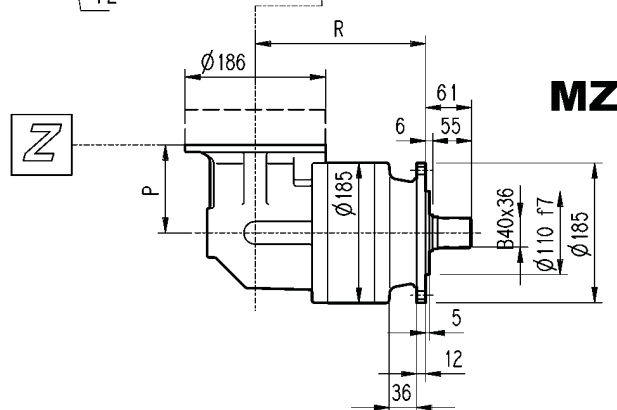
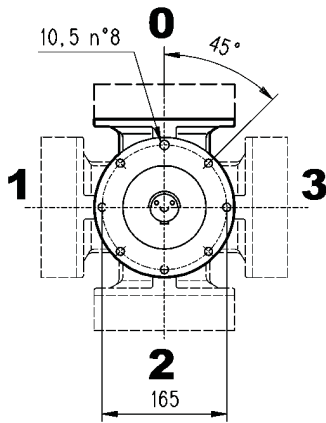
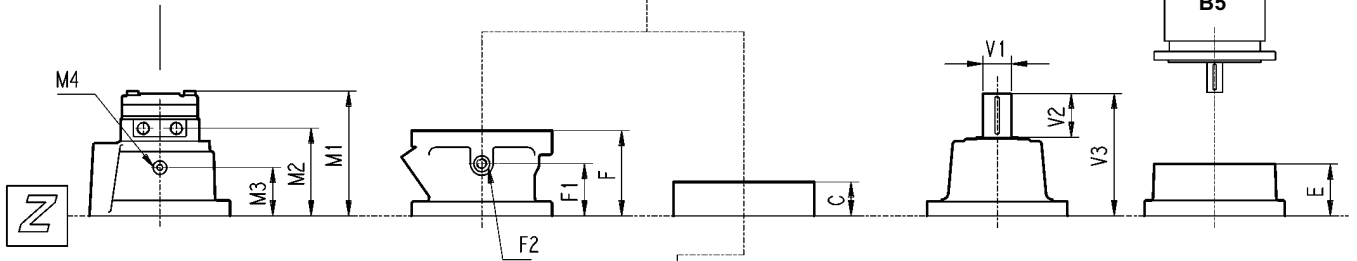
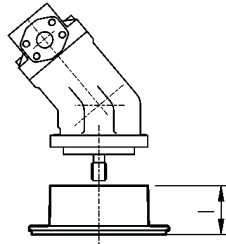

# 300R

		Motore idraulico / Hydraulic motor Hydraulikmotor/Moteur hydraulique						201			
		<b>MG</b>									
<b>cm<sup>3</sup></b>	<b>50</b>	<b>80</b>	<b>100</b>	<b>125</b>	<b>160</b>	<b>200</b>	<b>250</b>	M2	M3	M4	
<b>300R2</b>	156	162	166	-	-	-	-	113	60	1/4G	14

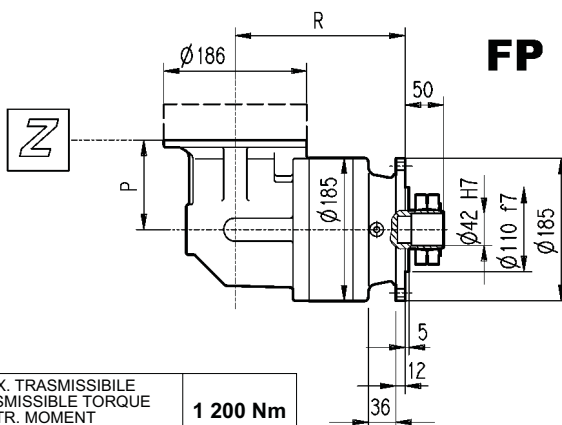
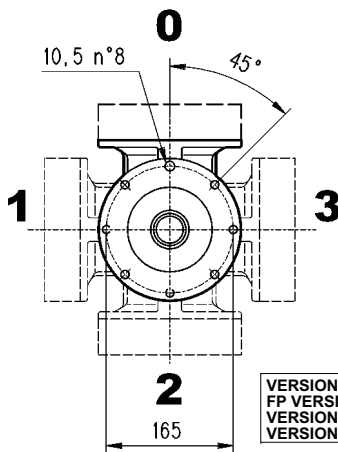
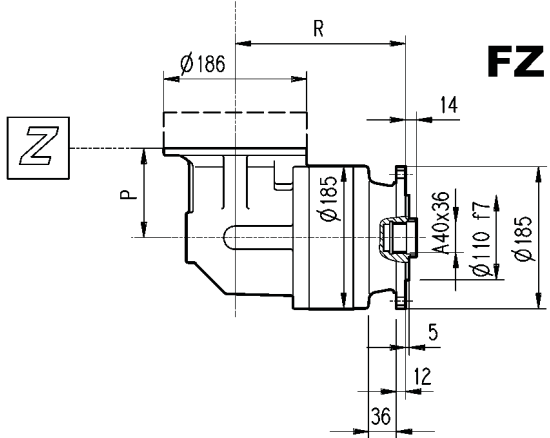
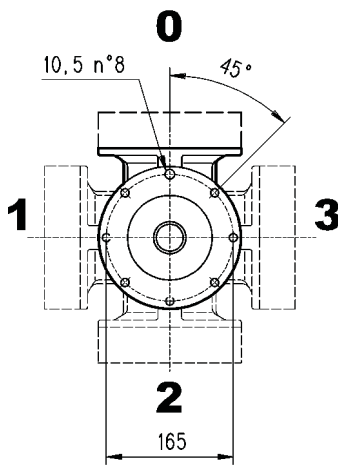
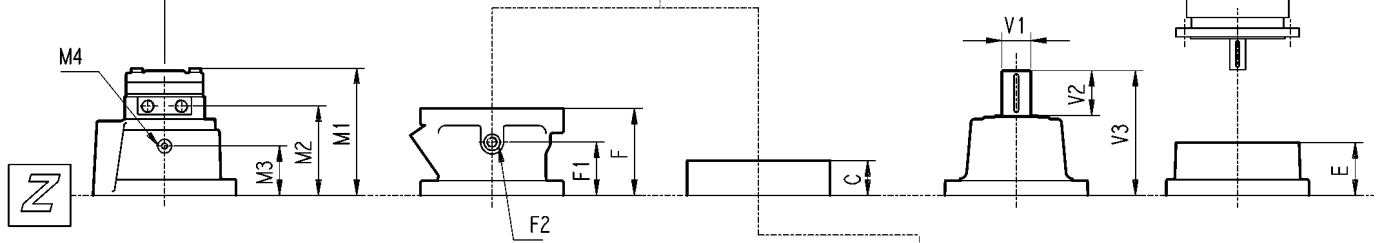
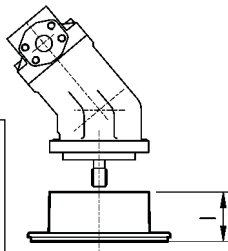

VERSIONE FP	COPPIA MAX. TRASMISSIBILE	<b>1 200 Nm</b>
FP VERSION	MAX. TRANSMISSIBLE TORQUE	
VERSION FP	MAX. ÜBERTR. MOMENT	
VERSION FP	COUPLE MAX. TRANSMISSIBLE	

	R				P					C	Entrata Input Antrieb Entrée	I	F	F1	F2	Tipo Type Typ Type	Entrata Input Antrieb Entrée	
	MZ	MC	FZ	FP		HZ	HC	PC	PZ									
<b>300 R2</b>	172	172	207	178	122	32	30	34	37	37	A	105	65	1/4 G	4	A	10	
<b>300 R3</b>	225	225	260	231	122	36	34	38	41	37	A	105	65	1/4 G	4	A	10	
<b>300 R4</b>	278	278	313	284	122	40	38	42	45	37	A	105	65	1/4 G	4	A	10	

	V1	V2	V3		V1	V2	V3		E					
									IEC 71	IEC 80	IEC 90	IEC 100	IEC 112	IEC 132
<b>300 R2</b>	24	36	137.5	6	38	58	158	7	65	84	84	94	94	114
<b>300 R3</b>	24	36	137.5	6	38	58	158	7	65	84	84	94	94	114
<b>300 R4</b>	24	36	137.5	6	38	58	158	7	65	84	84	94	94	114

**300L - 300R**

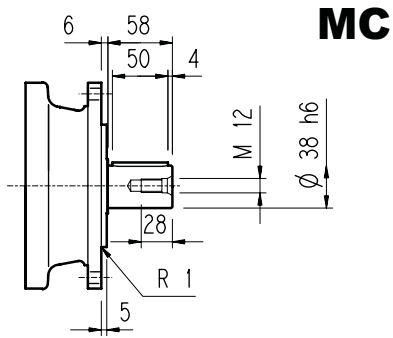

**MC**

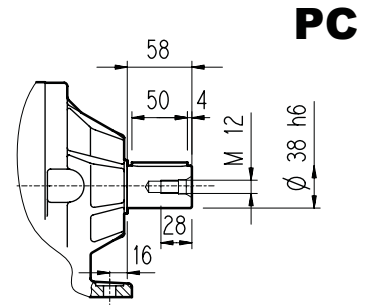
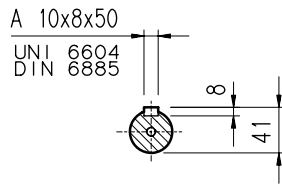

**PC**

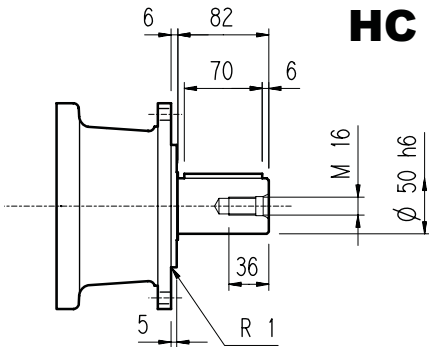

**HC**

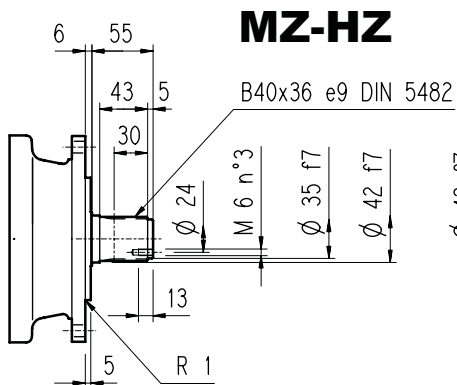
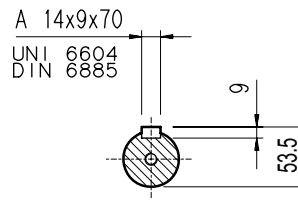

**MZ-HZ**

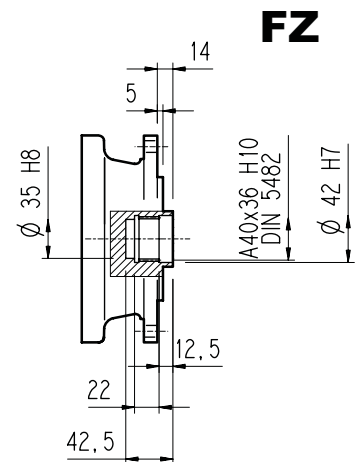
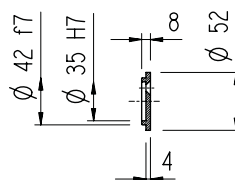

**FZ**

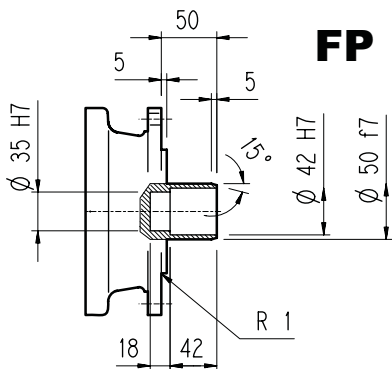

**FP**

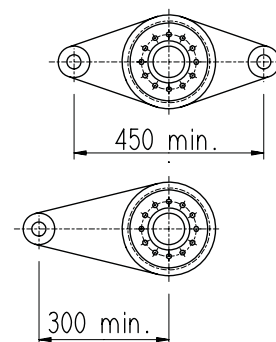
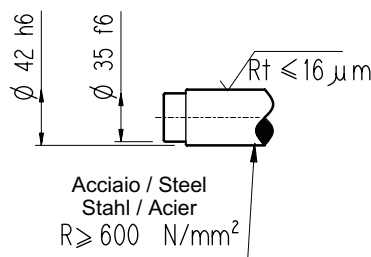

VERSIONE FP FP VERSION VERSION FP VERSION FP	COPPIA MAX. TRASMISSIBILE MAX. TRANSMISSIBLE TORQUE MAX. ÜBERTR. MOMENT COUPLE MAX. TRASMISSIBILE	<b>1 200 Nm</b>
---	--	-----------------

Flangia / Flange  
Flansch / Brides

**300L - 300R**  
**WOA**

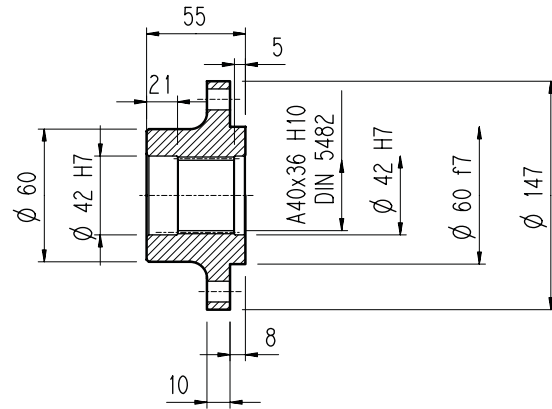
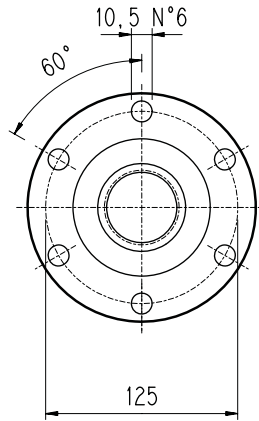
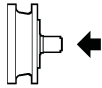

Materiale : Acciaio C40  
Material : Steel C40  
Material : Stahl C40  
Màterial : Acier C40

Pignoni per rotazione / Output pinions  
Ritzel / Pignons

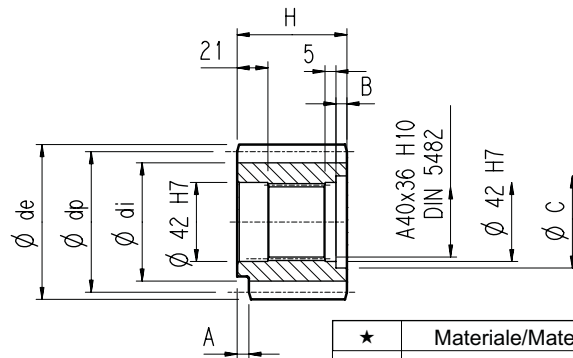
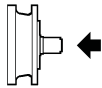

**P...**

	m	z	x	dp	di	de	H	A	B	C	★
<b>PBE</b>	4.5	14	0.507	63	56	75.5	55	0	0	0	■
<b>PCE</b>	5	14	0.500	70	62.5	84.8	65	0	10	53	■
<b>PDC</b>	6	12	0.250	72	61	84.8	59	14	4	54	■
<b>PDE</b>	6	14	0.500	84	73	99.6	65	0	10	54	■

★	Materiale/Material/Material/Màterial
■	Acciaio 39NiCrMo3 Bonificato Steel 39NiCrMo3 hardened and tempered Vergüteter Stahl 39NiCrMo3 Acier bonifié 39NiCrMo3
□	Acciaio 18NiCrMo5 Cementato e temprato Steel 18NiCrMo5 Case hardened Einsatzstahl 18NiCrMo5 Einsatzgehärtet Acier cementé et tempré 18NiCrMo5

Manicotti lisci / Sleeve couplings  
Naben / Manchons lisses a cannelure interieure

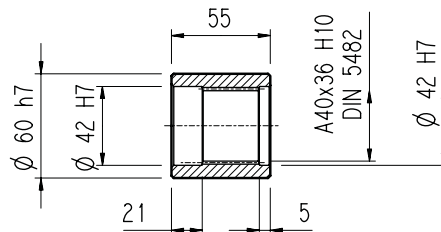
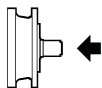

**MOA**

Materiale : Acciaio 16CrNi4  
Material : Steel 16CrNi4  
Material : Stahl 16CrNi4  
Màterial : Acier 16CrNi4

Barre scanalate / Splined bars  
Vielkeilwellen / Barre cannelée

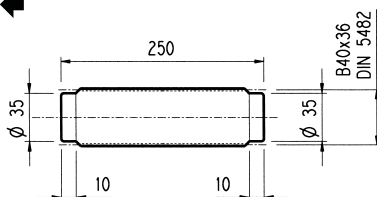
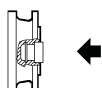

**BOA**

Mat. acciaio 18NiCrMo5 UNI 5331 da cementare e temprare 50-55 HRC  
Case hardening steel 18NiCrMo5 UNI 5331  
must be case hardened 50-55 HRC  
Material: Einsatzstahl 18NiCrMo5 UNI 5331  
muss einsatzgehärtet werden 50-55 HRC  
Acier 18 NiCrMo5 UNI 5331 doit être cémenté trempé 50-55 HRC

Giunto ad attrito / Shrink disc  
Schrumpfscheibe / Frette de serrage

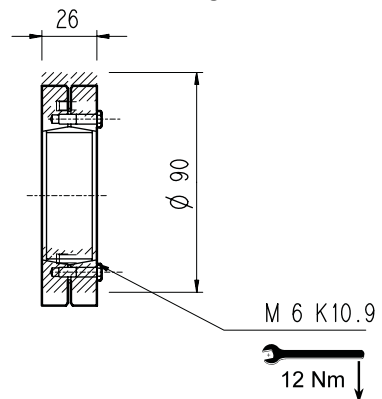
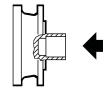

**GOA**

### 300L - 300R

Alberi veloci / Input shaft  
Antriebswellen / Arbres d'entrée

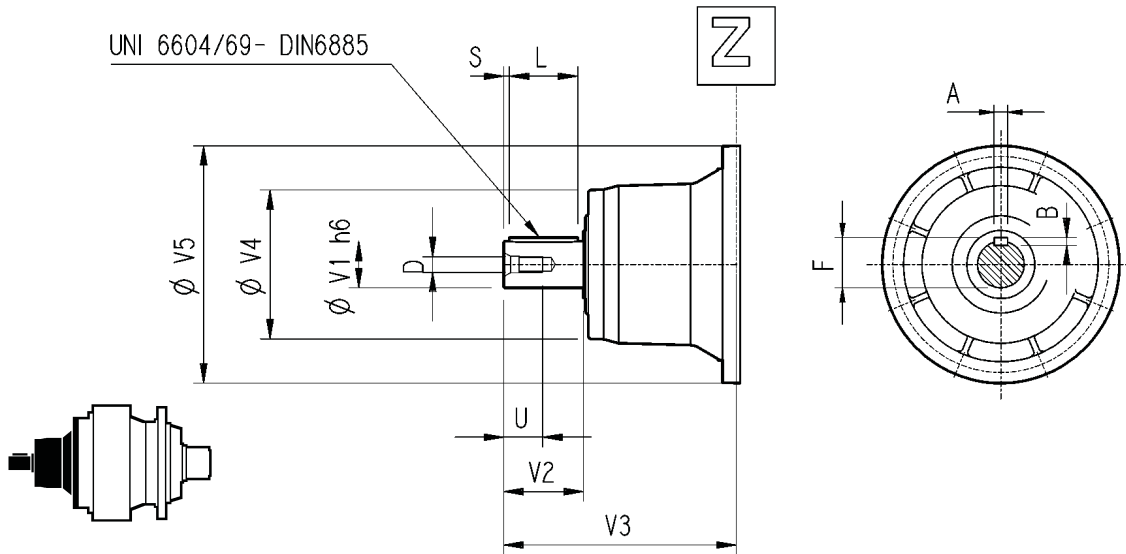

	CODE	V1	V2	V3	V4	V5	A	B	F	L	S	D	U
300 L1	V01A	24	36	137.5	120	186	8	7	27	30	3	M8	19
	V01B	38	58	158	120	186	10	8	41	50	4	M12	28
300 L2	V01A	24	36	137.5	120	186	8	7	27	30	3	M8	19
	V01B	38	58	158	120	186	10	8	41	50	4	M12	28
300 L3	V01A	24	36	137.5	120	186	8	7	27	30	3	M8	19
	V01B	38	58	158	120	186	10	8	41	50	4	M12	28
300 L4	V01A	24	36	137.5	120	186	8	7	27	30	3	M8	19
	V01B	38	58	158	120	186	10	8	41	50	4	M12	28
300 R2-R3-R4	V01A	24	36	137.5	120	186	8	7	27	30	3	M8	19
	V01B	38	58	158	120	186	10	8	41	50	4	M12	28

Dimensioni d'entrata senza predisposizione motore  
Input dimension without motor adaptor  
Maße für den Antrieb ohne Motoradapter  
Dimensions d'entrée sans prédisposition moteur

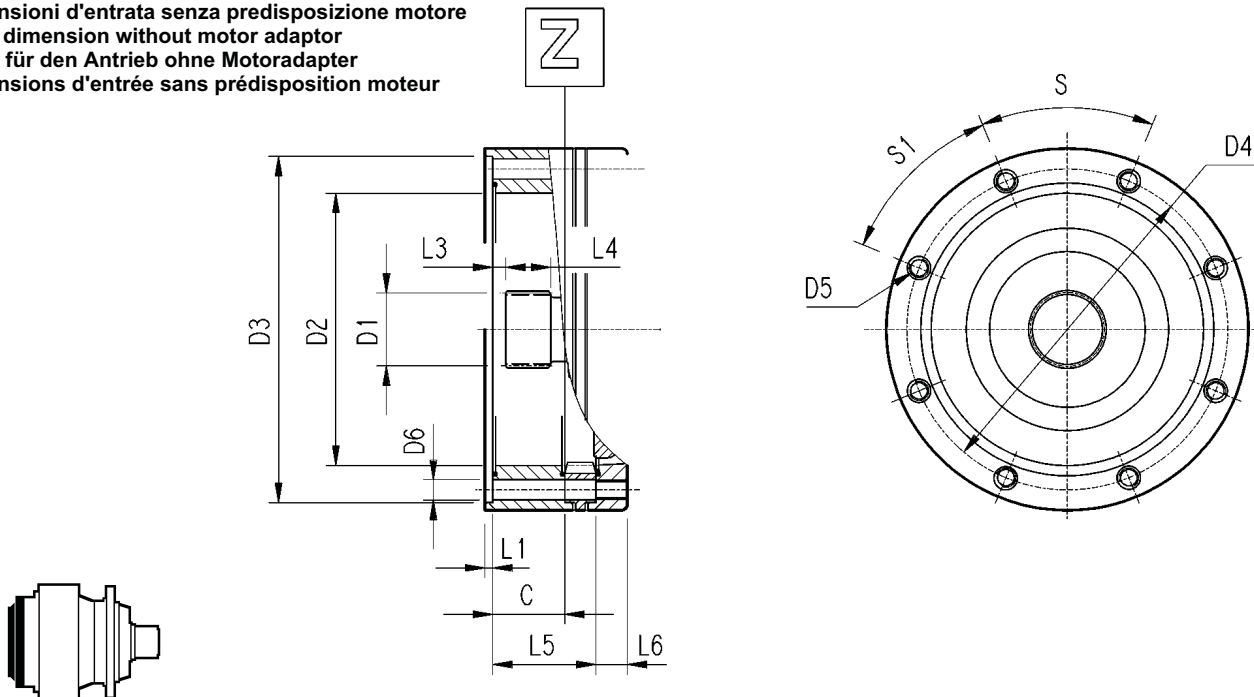

	C	D1	D2	D3	D4	D5	D6	L1	L2	L3	L4	L5	L6	S	S1	Entrata Input Antrieb Entrée
300 L1	37	40x36 DIN5482	140	178 H7	165	M10 n°8	11	4	/	9	18	53	18	45°	45°	A
300 L2	37	40x36 DIN5482	140	178 H7	165	M10 n°8	11	4	/	9	18	106	18	45°	45°	A
300 L3	37	40x36 DIN5482	140	178 H7	165	M10 n°8	11	4	/	9	18	159	18	45°	45°	A
300 L4	37	40x36 DIN5482	140	178 H7	165	M10 n°8	11	4	/	9	18	212	18	45°	45°	A
300 R2-R3-R4	37	40x36 DIN5482	140	178 H7	165	M10 n°8	11	4	/	9	18	37	18	45°	45°	A

### 300L - 300R

Carichi radiali ed assiali ammissibili sull'albero lento per un valore di  $Fh_2 : n_2 \cdot h = 10\ 000$

Permissible radial and axial loads on output shaft with  $Fh_2 : n_2 \cdot h = 10\ 000$

An der Ausgangswelle zulässige Radiallasten und Axialkräfte für einen Wert von  $Fh_2 : n_2 \cdot h = 10\ 000$

Charges radiales et axiales admissibles sur l'arbre lent pour une valeur de  $Fh_2 : n_2 \cdot h = 10\ 000$

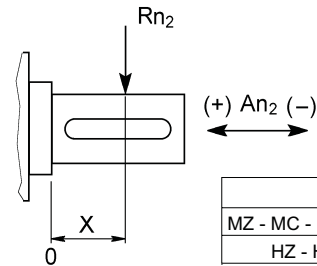
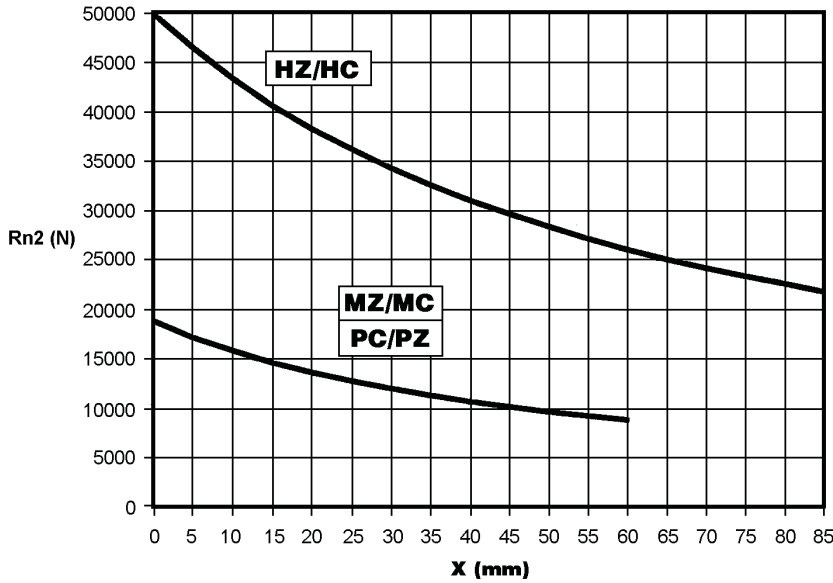

	An <sub>2</sub> (+)	An <sub>2</sub> (-)
MZ - MC - PC - PZ	20 000	15 000
HZ - HC	40 000	40 000

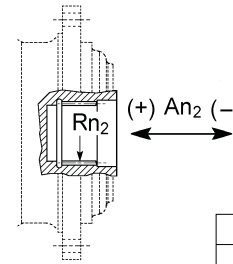

	Rn <sub>2</sub>	An <sub>2</sub> (+/-)
FZ	8 000	8 000

Fattore $fh_2$ correttivo per carichi sugli alberi Load corrective factor $fh_2$ on shafts Korrektionsfaktor $fh_2$ für wellenbelastungen Facteur de correction $fh_2$ pour charges sur les arbres	$Fh_2 = n_2 \cdot h$						
		10 000	25 000	50 000	100 000	500 000	1 000 000
$fh_2$	MZ-MC-PC-PZ-FZ	1	0.74	0.58	0.46	0.27	0.21
	HZ - HC	1	0.76	0.61	0.50	0.31	0.25

Carichi radiali ammissibili sull'albero veloce per un valore di  $Fh_1 : n_1 \cdot h = 250\ 000$

Permissible radial loads on input shaft with  $Fh_1 : n_1 \cdot h = 250\ 000$

An der Antriebswelle zulässige Radiallasten für einen Wert von  $Fh_1 : n_1 \cdot h = 250\ 000$

Charges radiales admises sur l'arbre d'entrée pour une valeur de  $Fh_1 : n_1 \cdot h = 250\ 000$

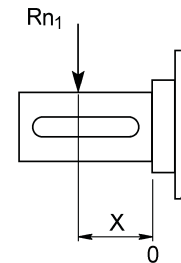
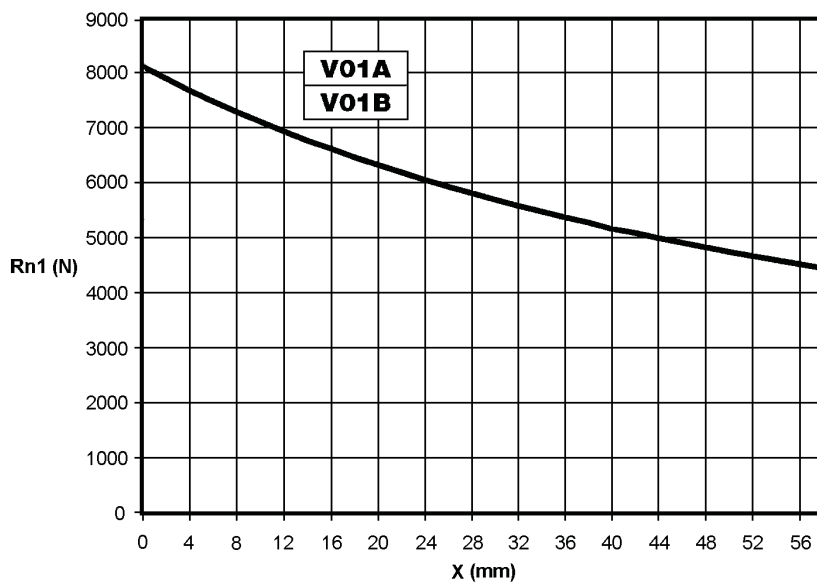

Fattore $fh_1$ correttivo per carichi sugli alberi Load corrective factor $fh_1$ on shafts Korrektionsfaktor $fh_1$ für wellenbelastungen Facteur de correction $fh_1$ pour charges sur les arbres	$Fh_1 = n_1 \cdot h$						
		250 000	500 000	1 000 000	2 000 000	5 000 000	10 000 000
$fh_1$	1	0.79	0.63	0.50	0.37	0.29	